



NEW HOLLAND

E16_B **E18_B**

NEW HOLLAND KOBELCO



	E16B	E18B
NET FLYWHEEL POWER		11.2 kW - 15 hp
OPERATING WEIGHT (MAX.)	1 700 kg	1 780 kg
REAR END SWING RADIUS		1 065 mm
BUCKET CAPACITY		0.028 - 0.069 m ³



NEW HOLLAND

CONSTRUCTION

BUILT AROUND YOU

E16B/E18B*

OUTSTANDING PERFORMANCE, HIGH PRODUCTIVITY

Engine complies with all the current standards:

- all the power you need with low fuel consumption
- advanced technological design minimises noise and emissions levels.

RESPECT FOR THE ENVIRONMENT

The E16B/18B respect the European "reduced noise level" as per directive 2000/14/EC phase 2.

Variable displacement pumps automatically adjust operating speed and power according to varying load conditions and allow optimisation of control and reduce fuel consumption.

The hydraulic system allows the driver to combine movement while driving.



Auxiliary hydraulic functions (single or double acting) with pipings/hoses up to the dipper:

- standard on E18B
- optional on E16B

Hydraulic "quick hitch" available on request.



Concave profile, foldable dozer blade:

- full width of the machine; pin-adjustable for wider track width on E18B
- achieves excellent grading and back filling performance and creates a stable excavating platform.

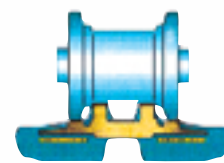

New, innovative design track rollers:

- wider, for increased stability
- better track retention
- longer track life

Simple track tension adjustment with grease pump.

Travel speeds: low 2.0 km/h high 3.5 km/h
Fingertip speed selector on travel lever.

* A product of the global alliance between New Holland and KOBELCOO

New three pillar canopy (FOPS, TOPS) or cab (FOPS, TOPS) available on both models. The most spacious operator's environment in the industry. The cab has a heater as standard and additional ventilation can be provided by the 'up & over' front windscreen or side-sliding window.



A user-friendly operating environment designed for long days of productive work and minimal operator fatigue: hand or foot operated travel controls, readily visible instrument panel, unrestricted visibility in all directions. Precise low effort, pilot operated joystick controls further enhance productivity.



E16B/E18B

MAINTENANCE & SERVICEABILITY



External sight gauges for easy checking of hydraulic and fuel levels.
New filters and battery layout.
Easy maintenance at ground level thanks to 360° 'all-round' service access:

- large opening, hinged rear engine hood
- two wide, side covers, easy to remove, allow an easier access to radiator, hydraulic and fuel tank.
- opening panel below the operator's seat gives access to electric fuses.
- Better access to fuel refill cup.



INTEGRATED-FLOW PUMP SYSTEM (THREE PUMPS) FOR TOTAL SIMULTANEOUS MOVEMENTS

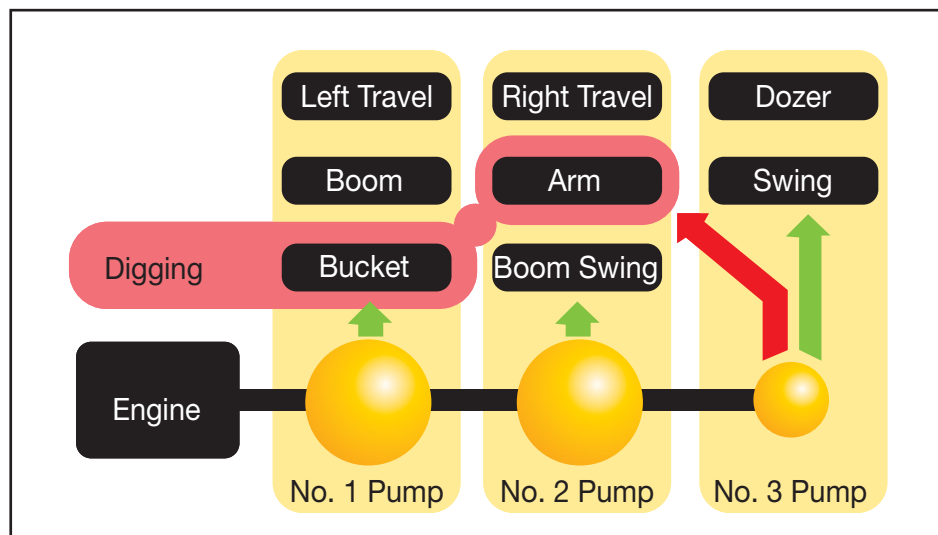

The instant the machine begins to dig, extra output from the third pump (which otherwise powers the swing and dozer circuits) is directed to the arm circuit for added power. This ensures fast and smooth arm operation even under heavy loads.

E16B

SPECIFICATIONS



MAIN FEATURES

Net flywheel power (ISO14396)	11.2 kW/15 hp
Operating weight:	
canopy	1580 kg
cab	1700 kg
Max digging depth (arm 1020 mm)	2200 mm
Max digging depth (long arm 1220 mm)	2400 mm
Breakout force:	
bucket	13.3 daN
dipper (short/long)	8.4/7.4 daN
Transport length (max)	3620 mm
Transport width	990 mm
Transport height (canopy/cab)	2340/2350 mm



ENGINE

Make	MITSUBISHI
Model	L3E
Type	4-stroke diesel, direct injection
Number of cylinders	3
Displacement	952 cm ³
Rated speed	2100 rpm
Max torque at 1800 rpm	53.5 Nm



ELECTRICAL SYSTEM

Batteries	1 x 40 Ah
Voltage	12 V
Alternator	40 A
Starter motor	1.7 kW



HYDRAULIC SYSTEM

Hydraulic System with two axial piston variable displacement pumps.	
Number of pumps	2
Total delivery	2 x 15,5 l/min
Max operating pressure (attach/travel)	206 bar
Max operating pressure (swing)	145 bar



SWING

Hydraulic motor	axial piston type
Swing speed	9.5 rpm
Boom slewing angle:	
left	80°
right	45°



UNDERCARRIAGE

Length of track on ground	1215 mm
Width	990 mm
Shoe width (Rubber track)	230 mm
Ground pressure (canopy/cab)	0.25/0.30 bar
Upper/lower rollers	plate/3
Travel speeds	1 or 2
Travel speed range (Rubber tracks)	2.0-2.0/3.5 km/h
Maximum continuous slope	58% (30°)



BLADE

Width x height	990 x 245 mm
Blade lift	210 mm
Blade lower	310 mm



CAPACITIES

	litres
Fuel	19.5
Coolant	3.5
Engine oil	3.0
Hydraulic System	15.0



E18B

SPECIFICATIONS



MAIN FEATURES

Net flywheel power (ISO14396)	11.2 kW/15 hp
Operating weight:	
canopy	1660 kg
cab	1780 kg
Max digging depth (arm 1020 mm)	2200 mm
Max digging depth (arm 1220 mm)	2400 mm
Breakout force:	
bucket	14.0 daN
dipper (short/long)	8,7/7,8 daN
Transport length (max)	3620 mm
Transport width (spanner IN/OUT)	990/1330 mm
Transport height (canopy/cab)	2340/2350 mm



ENGINE

Make	MITSUBISHI
Model	L3E
Type	4-stroke diesel, direct injection
Number of cylinders	3
Displacement	952 cm ³
Rated speed	2100 rpm
Max torque at 1800 rpm	53.5 Nm



ELECTRICAL SYSTEM

Batteries	1 x 40 Ah
Voltage	12 V
Alternator	40 A
Starter motor	1.7 kW



HYDRAULIC SYSTEM

Hydraulic System with two axial piston variable displacement pumps and one gear pump.

Number of pumps	2+1
Total delivery (axial piston pumps)	2 x 15.5 l/min
Gear pump delivery	10.9 l/min
Max operating pressure (attach/travel)	216 bar
Max operating pressure (swing)	140 bar



SWING

Hydraulic motor	axial piston type
Swing speed	9.0 rpm
Boom slewing angle:	
left	80°
right	45°



UNDERCARRIAGE

Length of track on ground	1215 mm
Width (spanner IN/OUT)	990/1330 mm
Shoe width (Rubber track)	230 mm
Ground pressure (canopy/cab)	0.27/0.31 bar
Upper/lower rollers	plate/3
Travel speeds	2
Travel speed range (Rubber tracks)	2.0/3.5 km/h
Maximum continuous slope	58% (30°)



BLADE

Width x height (folded/spanned)	990/1330 x 245 mm
Blade lift	210 mm
Blade lower	310 mm



CAPACITIES

	litres
Fuel	19.5
Coolant	3.5
Engine oil	3.0
Hydraulic System	15.0



E16B/E18B

DIMENSIONS (mm)

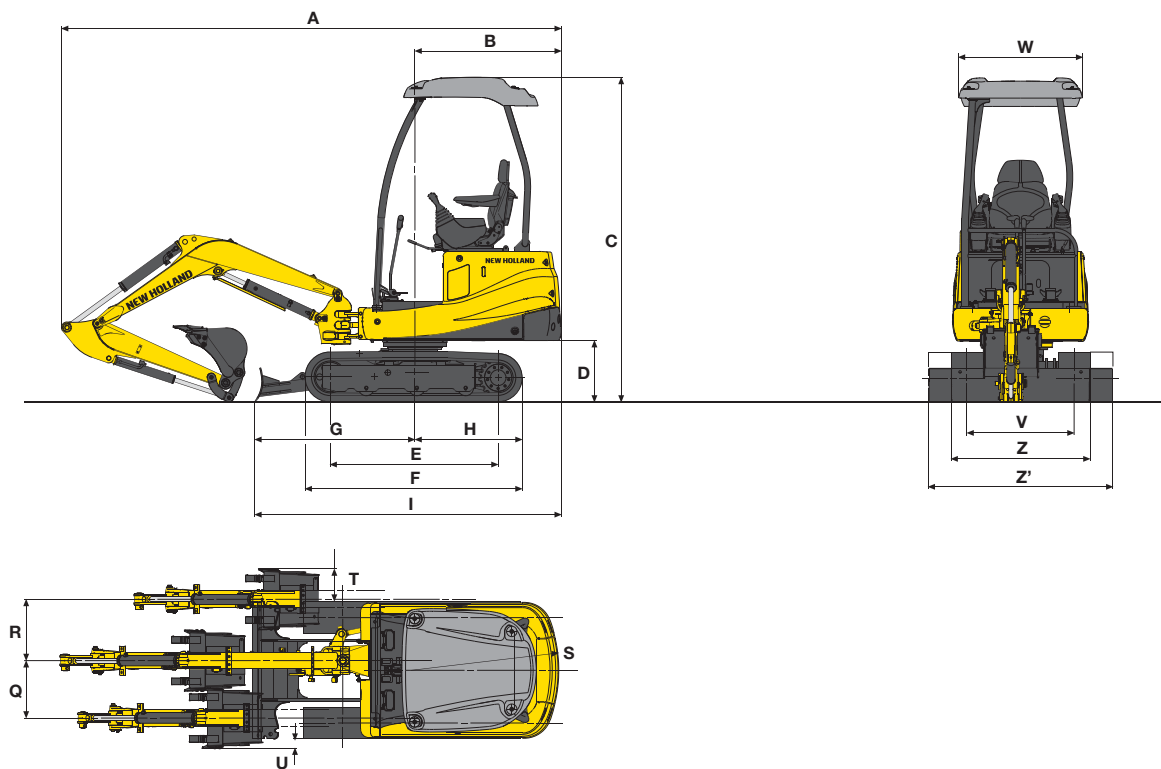

	A	B	C	D	E	F	G	H	I	Q	R	S	T	U	V	W	Z/Z'
E16B - E18B	3605	1055	2340/ 2350*	445	1215	1565	1155	775	2210	415	440	1065	240	70	760	890	990/ 1330**

* with cab

** with spanned blade

DIGGING PERFORMANCE E16B/E18B

DIPPERSTICK		1020	1220
A	mm	1525	1555
B	mm	3710	3900
C	mm	3800	3990
D	mm	2470	2595
E	mm	2060	2260
F	mm	3550	3675
G	mm	2200	2400
X	mm	210	210
Y	mm	310	310

BREAKOUT FORCE		1020	1220
Bucket	daN	13.3/14.0	13.3/14.0
Dipperstick	daN	8.4/8.7	7.4/7.8

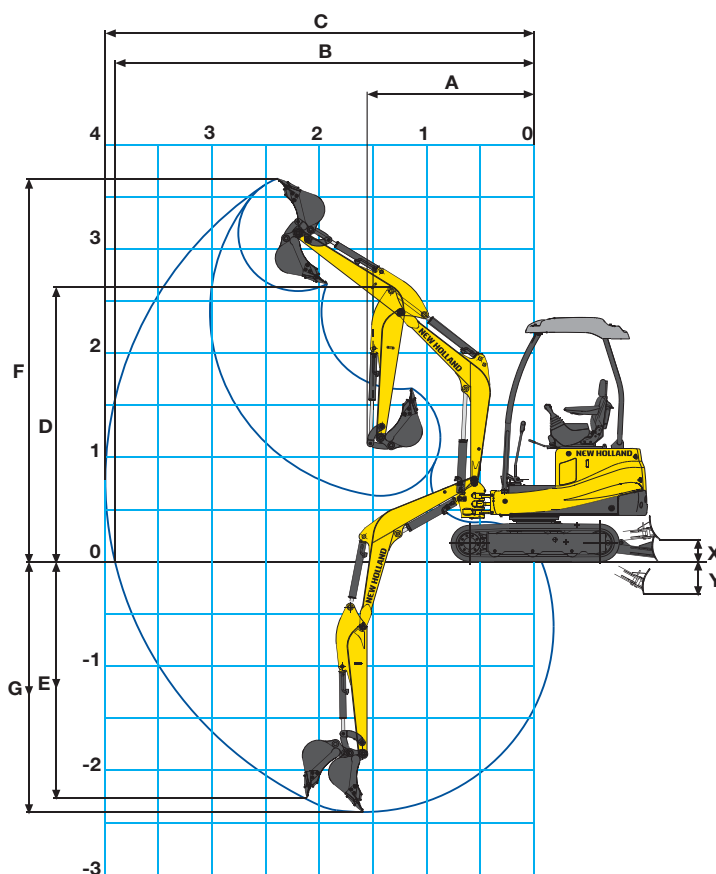

OPTIONS

- Arm length 1020 mm
- Arm length 1220 mm (not available on E16B one travel speed version)
- Bolt-on plate on Canopy for FOPS protection (standard on cab version of both models)
- Buckets:
 - 300 mm wide
 - 350 mm wide
- 400 mm wide
- 450 mm wide
- 500 mm wide
- Nibbler & Breaker piping (standard on E18B model)
- Quick connectors on N&B Piping-end
- Rotating Beacon
- Seat, mechanically suspended type
- Seat, standard type

Note: standard and optional equipment may vary by country. Consult your NEW HOLLAND dealer for specific details.



AT YOUR OWN DEALERSHIP

The information contained in this brochure is intended to be a general nature only. The NEW HOLLAND KOBELCO CONSTRUCTION MACHINERY S.p.A. company may at any time and from time to time, for technical or other necessary reasons, modify any of the details or specifications of the product described in this brochure. Illustrations do not necessarily show products in standard conditions. The dimensions, weights and capacities shown herein, as well as any conversion data used, are approximate only and are subject to variations within normal manufacturing techniques.

Published by NEW HOLLAND KOBELCO CONSTRUCTION MACHINERY S.p.A.
Printed in Italy - MediaCross Firenze - Cod. 30 450GB - Printed 06/09

Printed on recycled paper
CoC-FSC 000010 CQ Mixed sources



BUILT AROUND YOU

www.newholland.com