



# NEW HOLLAND

## **E175<sub>B</sub>**

**NEW HOLLAND KOBELCO**



NET FLYWHEEL POWER	93 kW - 125 hp
MAX OPERATING WEIGHT	18 950 kg
BUCKET CAPACITY	0.25 - 0.90 m <sup>3</sup>



**NEW HOLLAND**

**CONSTRUCTION**

**BUILT AROUND YOU**

# E175B\* THE PE

## TOP EFFICIENCY

Productivity (m<sup>3</sup>/l) + 9%

- **BREAK-OUT FORCE**  
bucket 13100 daN + 5%  
dipper 11900 daN + 5%
- **LIFTING CAPACITY +5%**
- **POWERFUL SWING**  
swing torque + 10 %



\* A product of the global alliance between CNH and KOBELCO

# PERFORMANCE

## SUPERIOR & SAFE DYNAMIC STABILITY

**T**he whole structure of E175B has been redesigned, to guarantee a perfect match with its higher performances, by improving position of centre of gravity, by optimising stresses distribution and by adopting higher quality steel plates. To eliminate bumps and shocks to the whole structure when the pistons reach their stroke end, cylinders have been equipped with automatic recovery and cushioning systems. In addition the undercarriage of EL version is now **6% longer**, thus effectively contributing to increased stability. **All this adds up to guarantee an excellent and safe machine with dynamic stability** when working in any kind of job and on all types of ground. This superb stability enhances the E175B **outstanding lifting capacity, increased by 5%. New Holland E175B features a Superior Breakout Force of 13100 daN or + 5%** which can be fully exploited, thanks to the weight strategically distributed in its structure, without unpleasant jumping effects.

## C.P.B. (Continuous Power Boost)

**Continuous Power Boost is a feature of excellence** of the E175B. Continuous Power Boost means that, if the operator is facing a very tough application, he can select this function (hydraulic pressure raises to 37.8 Mpa) **with no time limit**. Continuous Power Boost allows him to work without problems in job-site productivity and machine reliability.  
**A unique feature only offered by New Holland.**

- NEW larger displacement Environmentally Friendly Engine
- NEW generation hydraulic pumps
  - NEW hydraulic system
  - NEW longer undercarriage
- NEW flow & pressure set-up system
- NEW operator compartment



# E175B THE PO



## RESPECTING THE ENVIRONMENT

The E175B is compliant with European Directives concerning electromagnetic compatibility and noise level. The emissions of the new Tier 3A CNH engine have been dramatically reduced and are, as shown below, much lower than standard requirements.

**CO: 0.87, HC: 0.13, NOx: 3.72, Particulate: 0.19 (\*)**

In addition, this engine can use normal diesel, with up to 20% of Biodiesel added...  
...a real Environmentally Friendly machine.

(\*) all data are expressed in g/kWh

# POWER OF CONTROL



## NEW CNH ENGINE

The new CNH, 4 cylinders, 4.5 litres mechanical engine develops a power of 93 kW at 2200 rpm and a higher torque of 525 Nm at lower rpm... **an extremely flexible and responsive power plant.**

A larger displacement engine guarantees:

- Higher torque for higher productivity
- Longer lifespan
- Higher reliability



## NEW HYDRAULIC PUMPS

The E175B is equipped with two new generation low noise hydraulic pumps able to supply a high flow: **state-of-the-art pumps 9%, easy to control, prompt to react to all requirements and extremely silent.**

## SELECTRONIC CONTROL

Sensors are located in the pilot lines, sending signals to the on-board computer that are proportional to the manipulator's strokes. These signals are managed together with engine r.p.m. to tune the quantity of hydraulic oil requested **to guarantee extremely smooth and precise controls, excellent stability and steady speed during simultaneous operations.**



## LOW EFFORT & PRECISE JOYSTICKS

All machine movements can be smoothly controlled by **low effort joysticks...** a real, effective **Control of Power** allowing longer work times with less fatigue. The joystick illustrated is supplied as an option, together with rotating bucket circuit.

# E175B ADVANC



## NEW HYDRAULIC SYSTEM

### **T** EFFICIENCY AND CONTROLLABILITY

To obtain a Hydraulic System which is much more efficient, controllable, fast and powerful, and which consumes less fuel than previously, New Holland engineers have been working not only on pumps but also on a completely redesigned and refined Control Valve adding a second arm spool, increased swing output torque and new working mode selection functions. Movement speed has been increased and machine controllability improved, especially on operations that require combined movements. This outstanding characteristic is further enhanced by the new **H.A.O.A. Control**.

### **H** H.A.O.A. (Hydrotronic Active Operation Aid)

Hydrotronic Active Operation Aid is the most effective available combination of an extremely advanced electronic technology that provides a “just in time” comprehensive control of all machine functions, and a deeply refined and sophisticated hydraulic system.

H.A.O.A. continuously optimises hydraulic output according to operator and job demand, providing the best machine controllability, productivity, operator comfort and fuel savings.

# ED HYDRAULIC SYSTEM



## A.E.P. - (Advanced Electronic Processor)

A.E.P. is a new Electronic Processor that interacts with the operator for selecting and monitoring all main working parameters, maintenance notifications, self diagnosis and operating data storage.

All this information is displayed in the new monitor, which features a larger back-lit, easier to read digital display and analogic gauges.

Simply select the requested working mode and A.E.P. pre-sets the hydraulic system to accomplish the job in the easiest and most productive way:

- **S mode** for normal working operations

- **H mode** when maximum power is required

Two additional modes are available for special applications and to operate tools like breakers and crushers:

- **A mode** adjusts the attachment circuit for tools which require two way flow.

A dedicated switch on the dashboard, enables the operator to select two pumps oil flow

- **B mode** for attachments featuring one way flow only

Both in A and B working modes the operator, by using the buttons on the monitor, may adjust the flow by 10 l/min steps and the pressure by 10 bars steps to perfectly match the parameters of the attachment being used.

In addition, the operator can save to memory 9 combinations of flow and pressure in both A and B working modes, for a total of 18 combinations.

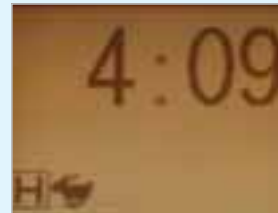
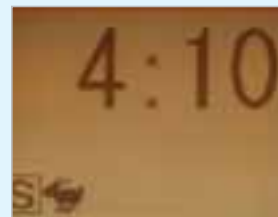

## D.O.C. (Dipperstick Optimised Control)

The newly redesigned Control Valve features a second spool dedicated to dipperstick operation. The movement “dipper out” is now achieved with a double flow, i.e., using the flow of the two pumps. The “dipper in” movement is even faster because of the double pump flow combined with the “Conflux”, or recirculation of unused oil which is diverted from return to tank.

**A perfect combination of speed, efficiency, precision and increased production.**

## OBJECT HANDLING KIT

European Standards state rules of thumb that do not allow free interpretation to each European Country. In case of object handling operations, an excavator can be used **only if certified by manufacturer** that it is equipped with all safety devices required by European Standards EN 474-5 : 1996. New Holland, confirming its commitment to grant high performances in an extremely safe environment, offers its customers the **optional Object Handling Kit** for maximum operator confidence.

# E175B HIGH RE

## TOP DESIGN & PRODU

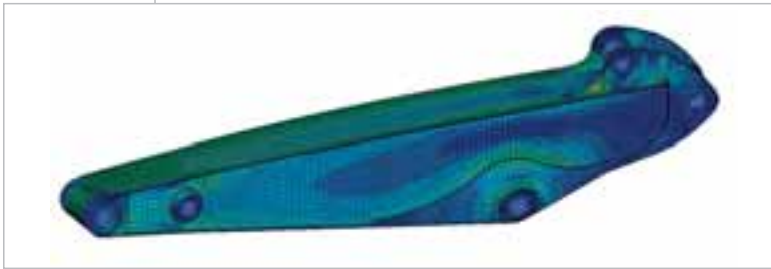
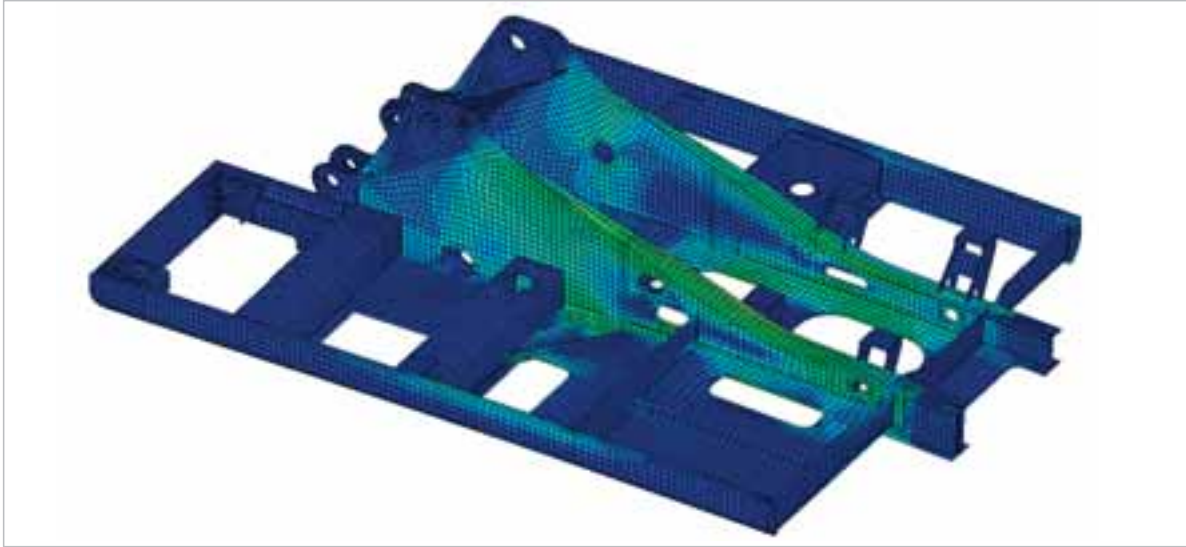

**B**ooms and Arms have been redesigned using advanced CAD (Computer Aided Design) and FEM (Finite Elements Methodology) Systems to get higher strength **only** in those areas where stresses are concentrated.

These sophisticated design methodologies are combined with the most advanced production technologies, providing high tensile steel plates that are cut, assembled and welded at the New Holland plant, which since many years holds the prestigious **"Vision 2000" Quality Certification**. The same innovative guidelines, to achieve **Heavy Duty** maximum strength together with outstanding torsional and flexional resistance, are applied in design and manufacture of upper structure and the undercarriage.



### T NEW BOOM & ARM

To further extend Arms durability even in rocky applications, New Holland offers as optional a robust Arm protection.

# RELIABILITY & DURABILITY PROTECTION TECHNOLOGIES



## NEW LONG UNDERCARRIAGE FOR BOTH VERSIONS

The length of the two versions EL & LC have been increased from 3090 to 3280 mm for enhanced durability, reliability, stability and performance, together with improved flotation in very wet ground and increased operator comfort.

## A TRACK GUIDE

A central mounted track guide is supplied as standard equipment on both track frames. If machine has to work and move in very uneven and rocky terrain, customers may choose the **optional 4 additional track guides** which are mounted, two per track frame, front and rear of the central ones. They contribute to keeping the chains on the rollers and protecting them at the same time, resulting in extended durability, maximum efficiency and safety.

**LENGTH INCREASED BY + 6% ⇒ HIGH STABILITY**

## BUCKET LINKAGE WITH DOUBLE BUSHING

The arm/bucket long-life internal bushing now has extra protection from wear due to contact with the bucket linkage, thanks to new additional external bushings made from anti-wear steel material. When the radial surface is worn these new bushings can be easily changed, thus increasing pin and bushing durability while reducing ownership costs.



# E175B OPERATOR



## NEW ONE-HAND WINDSCREEN OPENING

One-touch lock release simplifies opening and closing the front window, while a new mechanism makes it lighter.



## INSTRUMENT LAYOUT

In-cab switches and controls have been moved to the right-hand side in an easy to reach and more ergonomic position, thus improving operator comfort and convenience.



## NEW A. E. P. MONITOR

The newly designed A.E.P. Monitor, features analogical gauges which provide one sight advice, regardless of the operating environment.

The digital Display Screen has been enlarged to further enhance visibility. Maintenance information is clearly displayed and the self-diagnostic function provides an early warning detection of malfunctions.

Details of any previous breakdown or malfunction are also stored.

# R SAFETY AND COMFORT

## NEW EVO CAB EVOLUTION IN COMFORT AND SAFETY

**T**he interior of the cab has been completely re-designed to maximise operator comfort and to enable optimum operator performance. All switches and controls are now ergonomically positioned on the right side, easy to find and to reach. Enlarged side windows enhance the panoramic view.

The radio and the new, more powerful and effective automatic air-conditioning system are standard equipment, creating an agreeable working atmosphere regardless of external weather conditions. At the same time, new interior design and materials create an elegant feeling.

Six silicon liquid filled viscous dampers minimise vibrations.

The new, reinforced structure of the cab complies to ROPS and FOPS standards. Together with the optional front guard it's effectively contributing to operator safety.



### NEW COMFORTABLE SEAT

New comfortable contoured seat which can be adjusted in all directions and back and forth, together with or independently of side consoles.

The armrests, integrated on side consoles, can be lifted/lowered into four different positions and inclined, enabling the operator to set the correct position for maximum convenience and comfort.



## UNIQUE REAR CAMERA WITH “DEDICATED” IN CAB SCREEN

**T**his is a very special option, enhancing active safety for both the operator and others on the job site. The **“dedicated screen”** is mounted inside the cab and **is unique to New Holland**. It allows the operator, whilst working, to simultaneously control both the job going on behind his machine and the machine's functional parameters, thanks to the **A.E.P.** display, which operates constantly. A really unique and outstanding feature in terms of **safety and comfort**.





# E175B EASY MAIN

## DESIGNED TO EFFECTIVELY CUT OPERATING COSTS

### T CLEAN AND ACCESSIBLE LAYOUT

The new machine layout has been designed to make inspections, maintenance and servicing much easier and less time-consuming.

The engine oil filter, the fuel filter and the water separator are remote mounted and easy to reach from ground level. Both the fuel filter and the water separator, which removes contaminants and water, have an important function for engine performance and durability.

Cooling components (radiator, hydraulic oil cooler and intercooler) are now mounted in parallel, which means increased cooling efficiency for higher component reliability whilst being easier to check and clean.



The simplified layout of all vital components of the New Holland E175B under both the right and the left side panels makes maintenance much easier, less time consuming and less costly, and provides much better access for servicing. There is plenty of room in all compartments and most components are positioned in such a way to enable easy access from ground level. **An elegant and modern design added to state-of-the-art technology.**



### CENTRALISED GREASING

Maintenance procedures are also improved thanks to new grouped and centralised greasing points, which allow all boom wear points to be easily greased from ground level, after every 500 hours-long lasting intervals! On request, the E175B can be equipped with an **“Automatic Centralised Greasing System”** to supply all wear points of the machine with the right quantity of grease at the right time. A winning tool to **simultaneously reduce maintenance procedures and costs while improving machine reliability and durability.**



# MAINTENANCE & SERVICEABILITY

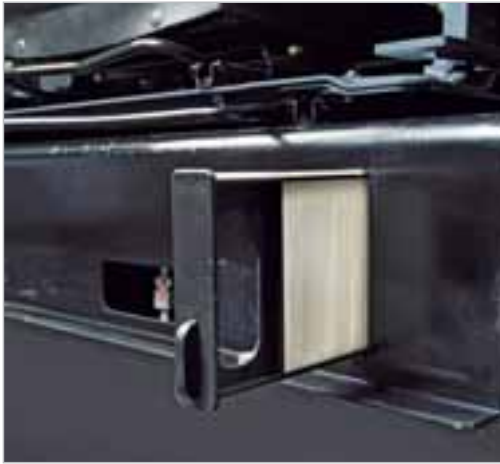

## INSIDE CAB MAINTENANCE

■ Airconditioning filter, positioned under the seat, can be easily removed without tools and from ground level, for easy cleaning.



■ Detachable two-piece floormat with handles for easy removal. A floor drain is located under the mat to facilitate inside cab cleaning.



## FUSES

The fuses are inside the cab, protected from dust and water as well as easy to reach and control.



## TOOL BOX

The tool box has been completely redesigned with a side-opening panel. It stores a new electric immersion type fuel pump, with automatic stop and alarm when the tank is full. The repositioning of the batteries (under the cooling components) and of the fuses (inside the cab) makes room in the compartment behind the cab for an additional wide and useful tool box.

# E175B

## SPECIFICATIONS



### ENGINE TIER 3A

Net flywheel power (ISO 14396/ECE R 120) .....93 kW/125 hp  
 Governed rpm .....2200  
 Make and model .....CNH 445TA/MLF  
 Type .....Diesel 4-stroke, direct injection, turbocharged and intercooler  
 Displacement .....4.5 l  
 Number of cylinders .....4  
 Bore x stroke .....104 x 132 mm  
 Maximum torque at 1250 rpm .....525 Nm

**Remote engine oil filter** for easy replacement

**Electronic engine rpm control**, dial type

**Auto-Idling selector** returns engine to minimum rpm when all controls are in neutral position

**-25°C outside temperature start** as standard equipment

*The engine complies with 97/68/EC standards TIER 3A*



### ELECTRICAL SYSTEM

Voltage .....24 V  
 Alternator .....70 A  
 Starter motor .....4 kW  
 Standard maintenance-free batteries .....2  
 Capacity .....100 Ah



### HYDRAULIC SYSTEM

**Redesigned Main Control Valve**, with added 2nd dipper spool and new Fail Safe Functions;

**H.A.O.A. (Hydrotronic Active Operation Aid)** to get the best hydraulic output according to operator/ application demand;

**E.S.S.C. (Engine Speed Sensing Control)** device, for total installed hydraulic power exploitation;

**D.O.C. (Dipper Optimised Control)** thanks to the 2nd dedicated spool in the Control Valve and to the Conflux system;

**C.P.B. (Continuous Power Boost)** to allow the operator to use extra power when and how long it is needed;

**A.E.P. (Advanced Electronic Processor)** interacting with the operator for selecting and monitoring main working parameters, maintenance programmes, self diagnosis and operating data storage thanks to the new monitor with a larger digital display and analogical gauges;

#### Two working modes:

- **S** = for normal digging operation;
- **H** = when maximum power is required;

#### Two Attachments modes:

- **A** = for attachments which require double pump flow;
- **B** = for attachments, such as breaker, featuring one way flow only.

**Standard double pump flow device and Diverter Valve automatically actuated** while selecting A;

**Pipe pressure discharge push button** to facilitate tooling changeover without piping oil leakage;

**Super Fine hydraulic filter (8 micron)** to grant perfect oil filtration, contributing to increase oil change interval

Main pumps:

Two variable delivery pumps with electronic delivery adjustment. Pumps automatically revert to zero delivery with controls in neutral.

Maximum delivery .....2 x 143 l/min

Piloting circuit gear type pump

Maximum delivery .....22 l/min

Maximum operating pressure:

- Equipment/travel .....34.3 MPa
  - Swing .....28.0 MPa
  - Power Boost .....37.8 MPa
- Hydraulic cylinders .....double effect
- Lift (2) - bore x stroke .....110 x 1150 mm
  - Dipperstick (1) - bore x stroke .....125 x 1290 mm
  - Bucket (1) - bore x stroke .....105 x 1025 mm
  - Positioning (only triple articulation) bore x stroke .....135 x 1010 mm

#### Independent hammer/positioning control



### TRANSMISSION

Type .....hydrostatic, two-speeds  
 Travel motors .....2, axial piston type, double displacement  
 Brakes .....oil bath discs type, automatically applied and hydraulically released

Final drive .....oil bath, planetary reduction  
 Gradeability (continuous) .....70% (35°)

Travel speeds:

- Low .....from 0 to 3.0 km/h
- High .....from 0 to 5.0 km/h

Drawbar pull .....171 kN

**Automatic DownShift device:** to move travel motors to maximum displacement position with selector on "high speed" position when greater traction is required.



### SWING

Swing motor .....axial piston type  
 Swing brake .....oil bath discs type, automatically applied and hydraulically released

Final drive .....oil bath, planetary reduction  
 Swing ring .....grease bath type  
 Swing speed .....11.5 rpm



### CAB AND CONTROLS

Sound suppressed cab with modern design, integrated ROPS and standard FOPS, tinted safety glass, insertable front window, transparent cab roof. Standard automatic air conditioning and radio.

Controls .....piloted  
 Two cross path manipulators actuate all equipment movements and upperstructure swing.

Two pedals with hand levers control all track movements, counter-rotation included.

A safety lever completely neutralizes the piloting circuit



### UNDERCARRIAGE

X-frame undercarriage design

Reinforced track chain with sealed bushings.

	E175BL	E175BLC
Track rollers (each side)	7	7
Carrier rollers (each side)	2	2
Length of track on ground (mm)	3280	3280
Gauge (mm)	1990	2190
Shoes (mm)	500-600-700	500 - 600-700
	800	800-900



### CAPACITIES

	litres
Lube oil	14.5
Coolant	18.0
Fuel tank	260.0
Hydraulic system	154.0

# STANDARD EQUIPMENT

- Automatic Air Conditioning System
- Automatic fuel electrical pump
- Auto-Idling device
- Batteries, maintenance free
- Centralised boom lubrication
- Double pumps flow
- Engine rpm electronic control
- EVO cab, FOPS and ROPS in compliance with Machine Directive
- Foot pedal with lever travel control
- Front seal hydraulic piping and connections
- Grease bath swing ring
- H.A.O.A. (Hydrotronic Active Operation Aid)
- HD chains
- Horn
- Hydraulically suspended cab with transparent roof
- Main control valve with antidrift valves
- Mechanical cushioned seat
- Multi-function monitor
- One-piece boom or triple articulation
- Power Boost device
- Radio set
- Rear view mirror on counter weight
- Swing and travel motors with automatic disc type brakes
- Tier-3A emissioned diesel engine
- Tool kit
- Two-speed intermittent operation windshield wiper
- Two travel speeds with Automatic DownShift device
- Two working lights on boom and one on upperstructure

# OPTIONS

- 2200 mm Dipperstick
- 2600 mm Dipperstick
- 3100 mm Dipperstick
- Antitheft device
- Arm protection
- Biological hydraulic oil
- Cab additional lights and rain protection
- Customer colour
- Front Guard protection for cab ( FOG in compliance with Machine Directive)
- Hammer and crusher circuit
- Hydraulic quick coupler provision
- Lower frame guard
- Multi-purpose, rock and heavy duty buckets with boom/bucket adjustment device
- Object Handling kit
- Pneumatic cushioned and heated seat
- Rear view camera with dedicated display
- Rotating bucket circuit
- Shoes:  
L version 500 - 600 - 700 - 800 mm  
LC version 500 - 600 - 700 - 800 - 900 mm
- Track guide

Note: standard and optional equipment may vary by country. Consult your NEW HOLLAND KOBELCO dealer for specific.

BUCKETS			E175B L			E175B LC			E175B L			E175B LC		
Width (mm)	Capacity (m <sup>3</sup> ) SAE J296 (ISO 7451)	Weight (Kg)	Dipper mm			Dipper mm			Dipper mm			Dipper mm		
			2200	2600	3100	2200	2600	3100	2200	2600	3100	2200	2600	3100
500	0.24	375												
780	0.43	475												
880	0.51	510												
1030	0.63	560												
1230	0.80	610												
1330	0.90	665												

- General digging work (specific weight of material < 1.8 t/m<sup>3</sup>)
- Slightly heavy digging work (specific weight of material < 1,5 t/m<sup>3</sup>)
- Loading work (specific weight of material < 1,2 t/m<sup>3</sup>)

# E175B

## ONE-PIECE BOOM

### DIMENSIONS (mm) - OPERATING WEIGHT

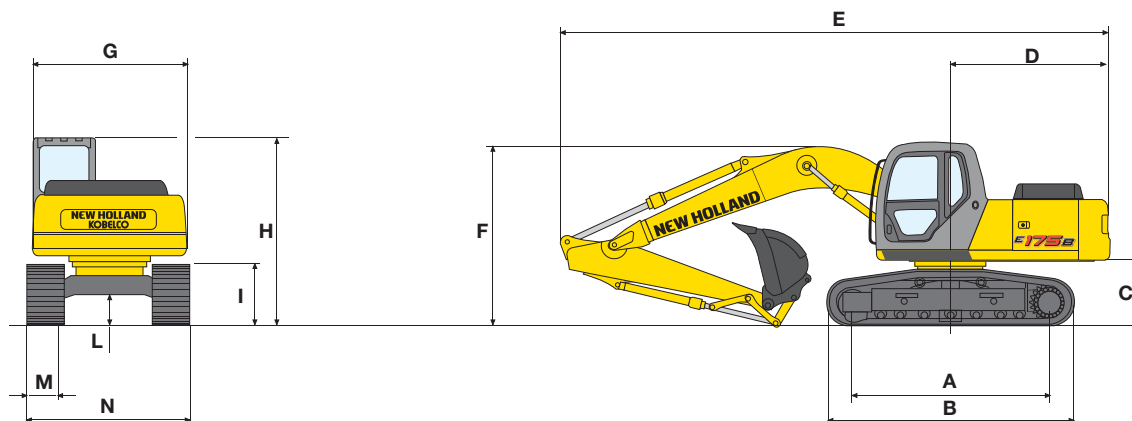

VERSIONS	A	B	C	D	E(*)	F(*)	G	H	I	L
					(1) 8725	(1) 2975				
<b>E175BL</b>	3280	4085	1020	2520	(2) 8670	(2) 2845	2490	3065	950	490
					(3) 8680	(3) 2930				
					(1) 8725	(1) 2975				
<b>E175BLC</b>	3280	4085	1020	2520	(2) 8670	(2) 2845	2490	3065	950	490
					(3) 8680	(3) 2930				

(\*) Dipperstick: (1) 2200 mm, (2) 2600 mm, (3) 3100 mm

		E175BL				E175BLC				
<b>M - Shoe width</b>	mm	500	600	700	800	500	600	700	800	900
<b>N - maximum width</b>	mm	2490	2590	2690	2790	2690	2790	2890	2990	3090
<b>Operating weight (*)</b>	kg	17250	17500	17750	18000	17550	17800	18050	18300	18550
<b>Ground pressure</b>	bar	0.46	0.39	0.34	0.30	0.47	0.39	0.34	0.30	0.27

(\*) With 3100 mm dipperstick and 0.50 m<sup>3</sup> bucket

## DIGGING PERFORMANCE

ONE PIECE BOOM = 5200 mm

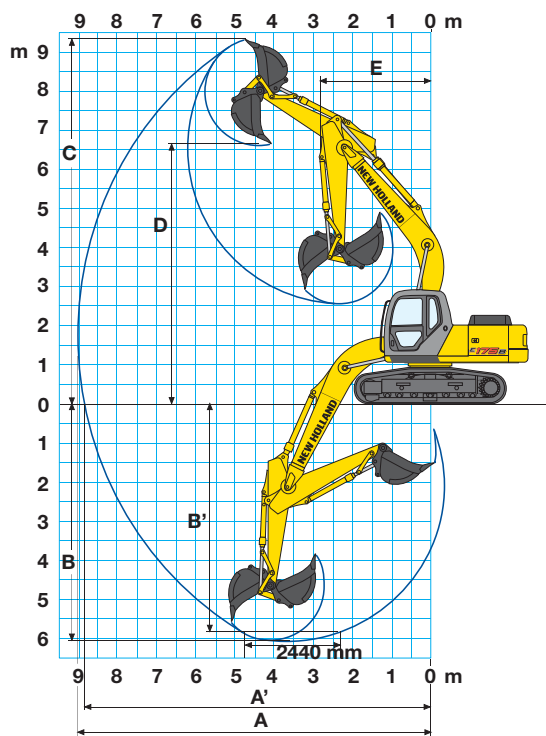

DIPPERSTICK		2200	2600	3100
A	mm	8675	9025	9520
A'	mm	8488	8845	9350
B	mm	5650	6050	6550
B'	mm	5400	5820	6365
C	mm	9155	9325	9685
D	mm	6490	6670	5060
E	mm	2990	2835	2895

BREAKOUT FORCE:				
BUCKET	daN	12050	12050	12050
DIPPERSTICK	daN	10900	9200	7750

WITH POWER BOOST ON				
BUCKET	daN	13100	13100	13100
DIPPERSTICK	daN	11900	10050	8450

# TRIPLE ARTICULATION

## DIMENSIONS (mm) - OPERATING WEIGHT

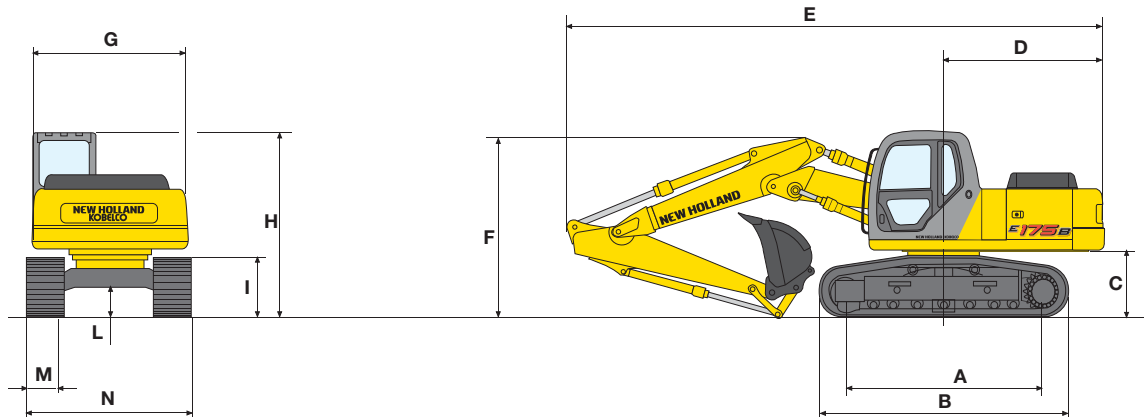

	A	B	C	D	E(*)	F(*)	G	H	I	L
					(1) 8575	(1) 3010				
<b>E175BL</b>	3280	4085	1020	2520	(2) 8520	(2) 2880	2490	3010	950	490
					(3) 8525	(3) 2995				
					(1) 8575	(1) 3010				
<b>E175BLC</b>	3280	4085	1020	2520	(2) 8520	(2) 2880	2490	3010	950	490
					(3) 8525	(3) 2995				

(\*) Dipperstick: (1) 2200 mm, (2) 2600 mm, (3) 3100 mm

	E175BL					E175BLC				
<b>M - Shoe width</b>	mm	500	600	700	800	500	600	700	800	900
<b>N - maximum width</b>	mm	2490	2590	2690	2790	2690	2790	2890	2990	3090
<b>Operating weight (*)</b>	kg	17650	17900	18150	18400	17950	18200	18450	18700	18950
<b>Ground pressure</b>	bar	0.53	0.45	0.39	0.34	0.54	0.45	0.39	0.35	0.31

(\*) With 3100 mm dipperstick and 0.50 m<sup>3</sup> bucket

## DIGGING PERFORMANCES

TRIPLE ARTICULATION max extension= 5045 mm / min extension= 3685 mm

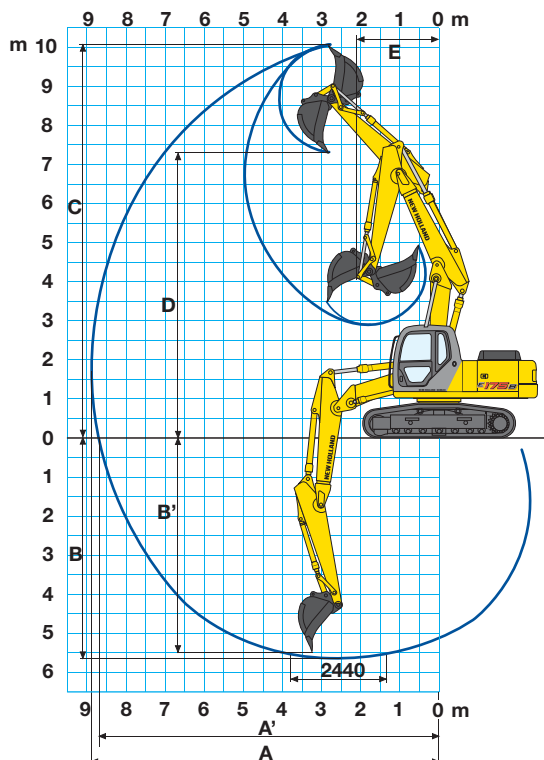

DIPPERSTICK	mm	2200	2600	3100
<b>A</b>	mm	8535	8890	9385
<b>A'</b>	mm	8345	8705	9210
<b>B</b>	mm	5270	5655	6160
<b>B'</b>	mm	5145	5540	6055
<b>C</b>	mm	9805	10070	10500
<b>D</b>	mm	7055	7320	7750
<b>E</b>	mm	2350	2110	2175

BREAKOUT FORCE:				
<b>Bucket</b>	daN	12050	12050	12050
<b>Dipperstick</b>	daN	10900	9200	7750

WITH POWER BOOST ON				
<b>Bucket</b>	daN	13100	13100	13100
<b>Dipperstick</b>	daN	11900	10050	8450

# E175B

## LIFTING CAPACITY

2200 mm DIPPERSTICK

VALUES ARE EXPRESSED IN TONNES

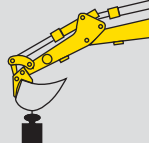
	RADIUS OF LOAD										
	3.0 m		4.5 m		6.0 m		7.5 m		AT MAX. REACH		REACH m
	FRONT	SIDE	FRONT	SIDE	FRONT	SIDE	FRONT	SIDE	FRONT	SIDE	

### E175BL TRIPLE ARTICULATION

HEIGHT	3.0 m		4.5 m		6.0 m		7.5 m		AT MAX. REACH		REACH m
+6.0 m			4.3 *	4.1 *					4.5 *	4.3 *	6.0
+4.5 m	6.4 *	6.1 *	4.6 *	4.4 *	4.4 *	3.5			4.3	2.7	6.8
+3.0 m	9.3 *	8.9 *	6.3 *	4.9	4.7 *	3.2			3.8	2.4	7.2
+1.5 m	11.3 *	7.7	7.4 *	4.5	4.7 *	3.0			3.6	2.3	7.3
0	10.5 *	7.4	7.5	4.3	4.8	2.9			3.7	2.3	7.1
-1.5 m	8.5 *	7.9	7.2 *	4.3	4.5	2.8			4.1	2.6	6.6
-3.0 m	7.4 *	7.0 *	6.2	3.9					5.0 *	3.0	5.5
-4.5 m											

### E175BL ONE-PIECE BOOM

HEIGHT	3.0 m		4.5 m		6.0 m		7.5 m		AT MAX. REACH		REACH m
+6.0 m					3.9 *	3.3			3.4 *	3.2 *	6.2
+4.5 m			4.7 *	4.7 *	4.3 *	3.3			3.4 *	2.5	7.0
+3.0 m	9.6 *	9.1 *	5.9 *	4.9	4.8 *	3.2			3.6	2.2	7.4
+1.5 m			6.8 *	4.5	4.8	2.9			3.5	2.1	7.5
0	9.0	8.0	7.1	4.3	4.7	2.8			3.6	2.1	7.3
-1.5 m	10.6	8.1	7.0	4.2	4.6	2.8			4.0	2.4	6.7
-3.0 m	8.7 *	8.2	6.0 *	4.3					4.6 *	3.1	5.7
-4.5 m	5.4 *	5.1 *							4.2 *	4.0 *	4.0

### E175BLC TRIPLE ARTICULATION

HEIGHT	3.0 m		4.5 m		6.0 m		7.5 m		AT MAX. REACH		REACH m
+6.0 m			4.1 *	4.1 *					4.3 *	4.3 *	6.0
+4.5 m	6.1 *	6.1 *	4.4 *	4.4 *	4.2 *	3.7			4.1	3.1	6.8
+3.0 m	8.9 *	8.9 *	6.0 *	5.3	4.5 *	3.6			3.8	2.7	7.2
+1.5 m	10.8 *	8.9	7.0 *	5.2	4.5 *	3.4			3.6	2.6	7.3
0	10.0 *	8.6	7.1	4.9	4.6	3.3			3.5 *	2.6	7.1
-1.5 m	8.1 *	8.1 *	6.9 *	5.0	4.3	3.3			4.2	3.0	6.6
-3.0 m	7.0 *	7.0 *	5.9	4.1					4.8 *	3.0	5.5
-4.5 m											

### E175BLC ONE-PIECE BOOM

HEIGHT	3.0 m		4.5 m		6.0 m		7.5 m		AT MAX. REACH		REACH m
+6.0 m					3.7 *	3.7 *			3.2 *	3.2 *	6.2
+4.5 m			4.7 *	4.7 *	4.1 *	3.7			3.2 *	2.9	7.0
+3.0 m	9.1 *	9.1 *	5.9 *	5.5	4.6 *	3.5			3.5 *	2.5	7.4
+1.5 m			6.8 *	5.2	5.1 *	3.3			3.6	2.4	7.5
0	8.6 *	8.6 *	7.2 *	4.9	5.0	3.2			3.8	2.4	7.3
-1.5 m	10.1 *	9.4	7.0 *	4.9	5.0	3.2			4.2	2.7	6.7
-3.0 m	8.3 *	8.3 *	6.0 *	4.9					4.4 *	3.5	5.7
-4.5 m	5.1	5.1							4.0 *	4.0 *	4.0

The table values refer to ISO 10567 for excavator equipped with bucket. The indicated load is no more than 87% of hydraulic system lift capacity or 75% of static tipping load. Values marked with an asterisk are limited by the hydraulic system.

# LIFTING CAPACITY

## 2600 mm DIPPERSTICK

VALUES ARE EXPRESSED IN TONNES

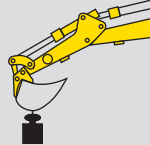
	RADIUS OF LOAD										
	3.0 m		4.5 m		6.0 m		7.5 m		AT MAX. REACH		REACH m
	FRONT	SIDE	FRONT	SIDE	FRONT	SIDE	FRONT	SIDE	FRONT	SIDE	

### E175BL TRIPLE ARTICULATION

HEIGHT	3.0 m		4.5 m		6.0 m		7.5 m		AT MAX. REACH		REACH m
+6.0 m			4.0 *	3.8 *	3.0 *	2.9 *			2.3 *	2.2 *	6.4
+4.5 m			4.4 *	4.2 *	3.4 *	3.2 *			2.2 *	2.1 *	7.2
+3.0 m	8.2 *	7.8 *	5.1 *	4.9 *	3.7 *	3.1			2.4 *	2.3 *	7.6
+1.5 m	11.2 *	8.0	6.6 *	4.6	4.1 *	3.0	2.8 *	2.0	2.6 *	2.0	7.7
0	11.0 *	7.6	7.6 *	4.4	4.7 *	2.9			3.2 *	2.1	7.5
-1.5 m	9.5 *	8.0	6.8 *	4.4	4.8 *	2.8			3.8 *	2.3	6.9
-3.0 m	6.5 *	6.2 *	4.8 *	4.5					3.3 *	3.0	6.0
-4.5 m											

### E175BL ONE-PIECE BOOM

HEIGHT	3.0 m		4.5 m		6.0 m		7.5 m		AT MAX. REACH		REACH m
+6.0 m					3.7 *	3.4			2.3 *	2.2 *	6.6
+4.5 m			4.5 *	4.3 *	4.0 *	3.3			2.2 *	2.1 *	7.3
+3.0 m	8.6 *	8.2 *	5.7 *	4.9	4.5 *	3.1	3.4 *	2.2	2.4 *	2.0	7.7
+1.5 m	10.1 *	8.3	6.8 *	4.5	4.8	2.9	3.4 *	2.1	2.6 *	1.9	7.8
0	11.1 *	8.0	7.4	4.3	4.7	2.8	3.4 *	2.0	3.2 *	2.0	7.6
-1.5 m	11.2 *	7.9	7.2	4.2	4.6	2.7			3.6	2.1	7.1
-3.0 m	9.5 *	8.1	6.6	4.2	4.6 *	2.8			4.4 *	2.7	6.2
-4.5 m	6.5 *	6.2 *	4.4 *	4.2 *					4.3 *	4.1 *	4.6

### E175BLC TRIPLE ARTICULATION

HEIGHT	3.0 m		4.5 m		6.0 m		7.5 m		AT MAX. REACH		REACH m
+6.0 m			3.8 *	3.8 *	2.9 *	2.9 *			2.2 *	2.2 *	6.4
+4.5 m			4.2 *	4.2 *	3.2 *	3.2 *			2.1 *	2.1 *	7.2
+3.0 m	7.8 *	7.8 *	4.9 *	4.9 *	3.5 *	3.5 *			2.3 *	2.3 *	7.6
+1.5 m	10.7 *	9.2	6.3 *	5.3	3.9 *	3.4	2.7 *	2.3	2.5 *	2.4	7.7
0	10.5 *	8.9	7.2 *	5.1	4.5 *	3.3			3.0 *	2.4	7.5
-1.5 m	9.0 *	9.0 *	6.5 *	5.0	4.6 *	3.3			3.6 *	2.7	6.9
-3.0 m	6.2 *	6.2 *	4.6 *	4.6 *					3.1 *	3.1 *	6.0
-4.5 m											

### E175BLC ONE-PIECE BOOM

HEIGHT	3.0 m		4.5 m		6.0 m		7.5 m		AT MAX. REACH		REACH m
+6.0 m					3.5 *	3.5 *			2.2 *	2.2 *	6.6
+4.5 m			4.3 *	4.3 *	3.8 *	3.7			2.1 *	2.1 *	7.4
+3.0 m	8.2 *	8.2 *	5.4 *	5.4 *	4.3 *	5.3	3.2 *	2.4	2.3 *	2.3 *	7.7
+1.5 m	9.6 *	9.6 *	6.5 *	5.2	4.8 *	3.3	3.2 *	2.3	2.5 *	2.5 *	7.8
0	10.6 *	10.6 *	7.2 *	4.9	5.0 *	3.2	3.2 *	2.3	3.0 *	2.2	7.6
-1.5 m	10.7 *	9.3	7.1 *	4.8	4.9	3.2			3.8	2.4	7.1
-3.0 m	9.0 *	9.0 *	6.3 *	4.9	4.4 *	3.2			4.2 *	3.0	6.2
-4.5 m	6.2 *	6.2 *	4.2 *	4.2 *					4.1 *	4.1 *	4.6

The table values refer to ISO 10567 for excavator equipped with bucket. The indicated load is no more than 87% of hydraulic system lift capacity or 75% of static tipping load. Values marked with an asterisk are limited by the hydraulic system.

# E175B

## LIFTING CAPACITY

### 3100 mm DIPPERSTICK

VALUES ARE EXPRESSED IN TONNES

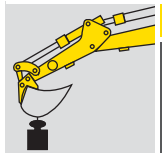

#### RADIUS OF LOAD

3.0 m		4.5 m		6.0 m		7.5 m		AT MAX. REACH		REACH m
FRONT	SIDE	FRONT	SIDE	FRONT	SIDE	FRONT	SIDE	FRONT	SIDE	

### E175BL TRIPLE ARTICULATION

HEIGHT											
+6.0 m			3.7*	3.5*	2.9*	2.8*			1.7*	1.6*	6.8
+4.5 m			4.0*	3.8*	3.0*	2.9*	1.9	1.8	1.6*	1.5*	7.5
+3.0 m	6.8*	6.5*	4.7*	4.5*	3.5*	3.2	2.6	2.1	1.7*	1.6*	8.0
+1.5 m	10.7*	8.1	6.0*	4.6	3.9*	3.0	2.8	2.0	1.8*	1.7*	8.1
0	11.2*	7.5	7.6	4.3	4.5*	2.9	2.9	2.0	2.1*	1.8	8.0
-1.5 m	10.3*	7.9	7.1*	4.3	4.8	2.8			2.7*	2.2	7.5
-3.0 m	7.8*	7.4*	5.6*	4.5	3.7*	2.8			4.2*	3.0	6.7
-4.5 m											

### E175BL ONE-PIECE BOOM

HEIGHT											
+6.0 m					3.4*	3.2*			1.6*	1.5*	7.2
+4.5 m					3.7*	3.3	2.7*	2.2	1.6*	1.5*	7.9
+3.0 m	7.4*	7.0*	5.1*	4.9*	4.2*	3.1	3.5	2.1	1.7*	1.6*	8.2
+1.5 m	10.5*	8.5	6.4*	4.6	4.8*	2.9	3.4	2.0	1.8*	1.7	8.3
0	9.8*	7.9	7.2*	4.3	4.6	2.8	3.3	1.9	2.1*	1.7	8.2
-1.5 m	11.4*	7.8	7.1	4.1	4.5	2.7	3.3	1.9	2.6*	1.8	7.7
-3.0 m	10.1*	7.9	6.8*	4.1	4.5	2.7			3.8	2.2	6.8
-4.5 m	7.7*	7.3*	5.3*	4.2					4.0*	3.2	5.5

### E175BLC TRIPLE ARTICULATION

HEIGHT											
+6.0 m			3.5*	3.5*	2.8*	2.8*			1.6*	1.6*	7.0
+4.5 m			3.8*	3.8*	2.9*	2.9*	1.8*	1.8*	1.5*	1.5*	7.7
+3.0 m	6.5*	6.5*	4.5*	4.5*	3.3*	3.3*	2.5*	2.4	1.6*	1.6*	8.1
+1.5 m	10.2*	9.4	5.7*	5.3	3.7*	3.4	2.7*	2.4	1.7*	1.7*	8.2
0	10.7*	8.8	7.3*	5.0	4.3*	3.3	2.8*	2.3	2.0*	2.0*	8.0
-1.5 m	9.8*	9.3	6.8*	5.0	4.7*	3.2			2.6*	2.4	7.5
-3.0 m	7.4*	7.4*	5.3*	5.2	3.5*	3.2			4.0*	3.1	6.6
-4.5 m											

### E175BLC ONE-PIECE BOOM

HEIGHT											
+6.0 m					3.2*	3.2*			1.5*	1.5*	7.2
+4.5 m					3.5*	3.5*	2.6*	2.5	1.5*	1.5*	7.9
+3.0 m	7.0*	7.0*	4.9*	4.9*	4.0*	3.6	3.5*	2.4	1.6*	1.6*	8.2
+1.5 m	10.0*	9.9	6.1*	5.2	4.6*	3.4	3.6	2.3	1.7*	1.7*	8.3
0	9.3*	9.3	6.9*	4.9	4.9	3.2	3.5	2.2	2.0*	2.0*	8.2
-1.5 m	10.9*	9.2	7.1*	4.8	4.8	3.1	3.4	2.2	2.5*	2.2	7.7
-3.0 m	9.6*	9.3	6.5*	4.7	4.7*	3.1			3.6*	2.6	6.8
-4.5 m	7.3*	7.3*	5.0*	4.9					3.8*	3.7	5.5

The table values refer to ISO 10567 for excavator equipped with bucket. The indicated load is no more than 87% of hydraulic system lift capacity or 75% of static tipping load. Values marked with an asterisk are limited by the hydraulic system.

# PARTS & SERVICE



**T**he New Holland dealer network is, in itself, the best guarantee of continued productivity for the machines it delivers to its customers. New Holland service technicians are fully equipped to resolve all maintenance and repair issues, with each and every service point providing the high standards they are obliged to observe under New Holland's stringent quality guidelines. The New Holland global parts network ensures fast, reliable, replacement parts for less downtime, increased productivity and, of course, profitable operation for its customers.

## FINANCIAL SERVICES

**A** critical business partner and leading finance solutions provider, CNH Capital is making it easier than ever for you to acquire and finance top quality construction equipment.

Whether you are operating your own equipment, or managing a fleet of several hundred units, CNH Capital's focus is on you, our customer, your business success and the success of the dealer network that supports you.

By listening to your needs, and those of our construction equipment dealers, and by offering the right mix of products, flexible terms and competitive finance rates, CNH Capital strengthens the bond between our customers, our dealers and our manufacturing facilities.

When the best equipment deserves the best financing solution, you can count on CNH Capital as a specialist in the field of construction equipment.

With CNH Capital, let us find the best financing solution to meet your needs so you can focus on your day to day business and on getting the very best out of your equipment.



# NEW HOLLAND. THE POWER OF A GLOBAL BRAND

New Holland is a global brand with a key position in the Construction Equipment business. It supplies a complete range of 13 product lines and 80 basic models split into Compact line and Heavy line. It operates in all the main markets, such as Europe, North and Latin America, Africa, Asia and Middle East with the same technology and under the same logo and brand. It manufactures durable, safe and productive machines aimed at supporting customers in developing their own business. Dealers are company partners. They play an important role to support the brand in their territories through intense professional relationship with Customers. New Holland is reinforced by its global alliance with Kobelco: world leader in hydraulic excavator technology.



AT YOUR OWN DEALERSHIP

The information contained in this brochure is intended to be a general nature only. The NEW HOLLAND KOBELCO CONSTRUCTION MACHINERY S.p.A. company may at any time and from time to time, for technical or other necessary reasons, modify any of the details or specifications of the product described in this brochure. Illustrations do not necessarily show products in standard conditions. The dimensions, weights and capacities shown herein, as well as any conversion data used, are approximate only and are subject to variations within normal manufacturing techniques.

Published by NEW HOLLAND KOBELCO CONSTRUCTION MACHINERY S.p.A.  
Printed in Italy - MediaCross Firenze - Cod. 31 417GB - Printed 02/11

Printed on recycled paper  
CoC-FSC 000010 CQ Mixed sources



ELEMENTAL  
CHLORINE  
FREE  
GUARANTEED



BUILT AROUND YOU

[www.newholland.com](http://www.newholland.com)