



NEW HOLLAND

E485B

NEW HOLLAND KOBELCO



	E485B-LCH	E485B-BEH
NET FLYWHEEL POWER	258 kW - 346 hp	
OPERATING WEIGHT (MAX)	50 250 kg	49 600 kg
BUCKET CAPACITY	1.6 - 2.2 m ³	1.6 - 2.6 m ³



NEW HOLLAND

CONSTRUCTION

BUILT AROUND YOU

E485B*

THE

C.P.B. (Continuous Power Boost)

Continuous Power Boost is a feature of excellence on the E485B. Continuous Power Boost means that, if the operator is facing a very tough application, he can select this function (hydraulic pressure raises to 34.3 Mpa) **with no time limit.** Continuous Power Boost allows him to maintain production and assures machine reliability. **A unique feature only offered by New Holland.**

- **NEW** HINO Common Rail engine, more powerful and environmentally friendly
- **NEW** generation hydraulic system
- **NEW** hydraulic system
- **NEW** generation hydraulic pumps
- **NEW** heavy duty booms and stronger undercarriage
- **NEW** operator compartment

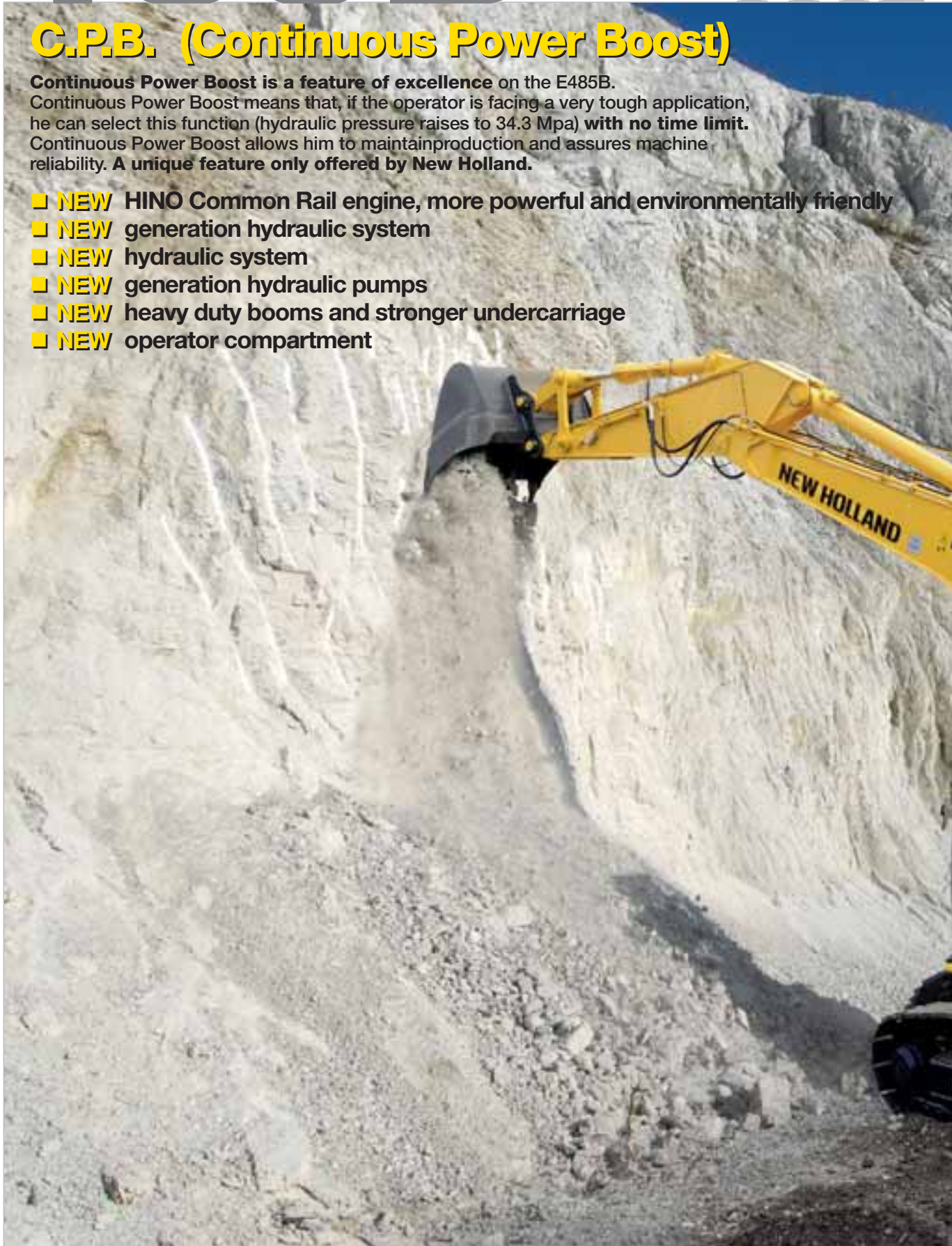

* A product of the global alliance between New Holland and KOBELCO

PERFORMANCE

SUPERIOR & SAFE DYNAMIC STABILITY

The whole structure of the E485B has been redesigned and improved to guarantee a perfect match between with it's high performance and by better positioning of it's centre of gravity, by optimising distribution of stress and by adopting higher quality steel plates.

To eliminate bumps and shocks to the whole structure when the pistons reach their stoke end, cylinders have been equipped with automatic recovery and cushioning systems.

The long undercarriage of both LCH and BEH versions, together with the weight strategically distributed in its structure, contribute to enhance machine stability while avoiding unpleasant jumping effects even in tough digging conditions.



E485B THE PO



RESPECTING THE ENVIRONMENT

The E485B is compliant with European Directives concerning electromagnetic compatibility and noise level. The emissions of the new Tier 3A HINO engine have been dramatically reduced and are, as shown below, much lower than standard requirements.

CO: 0.56, HC: 0.08, NOx: 3.44, Particulate: 0.11 (*)

...a real Environmentally Friendly machine.

(*) all data are expressed in g/kWh



POWER OF CONTROL



NEW COMMON RAIL ENGINE

The new turbo, aftercooled, electronically controlled HINO engine, features a multiple injector, high pressure, common rail technology for excellent fuel economy and sensible reduction of noise and pollution. A large displacement, common rail engine guarantees:
Lower fuel consumption, High torque for high productivity, Longer lifespan, Higher reliability.



NEW HYDRAULIC PUMPS

The E485B is equipped with two new generation low noise hydraulic pumps: **state-of-the-art pumps, which are easy to control, react promptly to all requirements and are extremely quiet.**

ELECTRONIC CONTROL

Sensors are located in the pilot lines, sending signals to the on-board computer that are proportional to the manipulator's strokes. These signals are managed together with engine r.p.m. to tune the quantity of hydraulic oil requested **to guarantee extremely smooth and precise controls, excellent stability and steady speed during simultaneous operations.**



LOW EFFORT & PRECISE JOYSTICKS

All machine movements can be smoothly controlled by **low effort joysticks... a real, effective Control of Power** allowing longer work times with less fatigue. The joystick illustrated is supplied as an option, together with rotating bucket circuit.

E485B ADVANC



NEW HYDRAULIC SYSTEM

EFFICIENCY AND CONTROLLABILITY

To obtain a Hydraulic System which is much more efficient, controllable, fast and powerful, and which consumes even less fuel than previously, New Holland engineers have been working not only on pumps but also on a completely redesigned and refined Control Valve adding a second arm spool and new working mode selection functions. Movement speed has been increased and machine controllability improved, especially on operations that require combined movements.

This outstanding characteristic is further enhanced by the new **H.A.O.A. Control**.

H.A.O.A. (Hydrotronic Active Operation Aid)

Hydrotronic Active Operation Aid is the most effective available combination of an extremely advanced electronic technology that provides a "just in time" comprehensive control of all machine functions, and a deeply refined and sophisticated hydraulic system. H.A.O.A. continuously optimises hydraulic output according to operator and job demand, providing the best machine controllability, productivity, operator comfort and fuel savings.

ED HYDRAULIC SYSTEM



A.E.P. - (Advanced Electronic Processor)

A.E.P. is a new Electronic Processor that interacts with the operator for selecting and monitoring all main working parameters, maintenance notifications, self diagnosis and operating data storage.

All this information is displayed in the new monitor, which features a larger back-lit, easier to read digital display and analogic gauges.

Simply select the requested working mode and A.E.P. pre-sets the hydraulic system to accomplish the job in the easiest and most productive way:

- **S mode** for normal working operations
 - **H mode** when maximum power is required
- Two additional modes are available for special applications and to operate tools like breakers and crushers:
- **A mode** adjusts the attachment circuit for tools which require two way flow.

A dedicated switch on the dashboard, enables the operator to select oil flow through two pumps

- **B mode** for attachments featuring one way flow only

Both in A and B working modes the operator, by using the buttons on the monitor, may adjust the flow by 10 l/min steps and the pressure by 10 bars steps to perfectly match the parameters of the attachment being used.

In addition, the operator can save to memory 9 combinations of flow and pressure in both A and B working modes, for a total of 18 combinations.

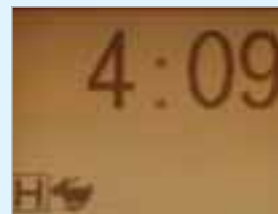
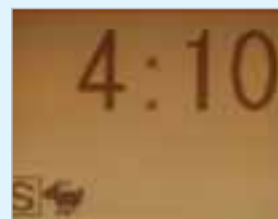

D.O.C. (Dipperstick Optimised Control)

The newly redesigned Control Valve features a second spool dedicated to dipperstick operation. The movement “dipper out” is now achieved with a double flow, i.e., using the flow of the two pumps. The “dipper in” movement is even faster because of the double pump flow combined with the “Conflux”, or recirculation of unused oil which is diverted from return to tank.

A perfect combination of speed, efficiency, precision and increased production.

OBJECT HANDLING KIT

European Standards rules are not open to interpretation by European Countries. In case of object handling operations, an excavator can be used **only if certified by manufacturer** that it is equipped with all safety devices required by European Standards EN 474-5 : 1996.

New Holland, confirming its commitment to grant high performances in an extremely safe environment, offers its customers the **optional Object Handling Kit** for maximum operator confidence.

E485B HIGH RE

TOP DESIGN & PRODU

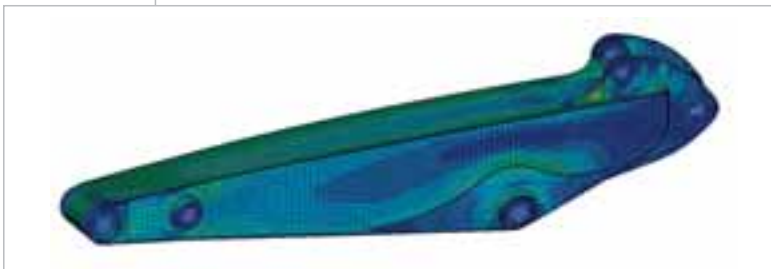
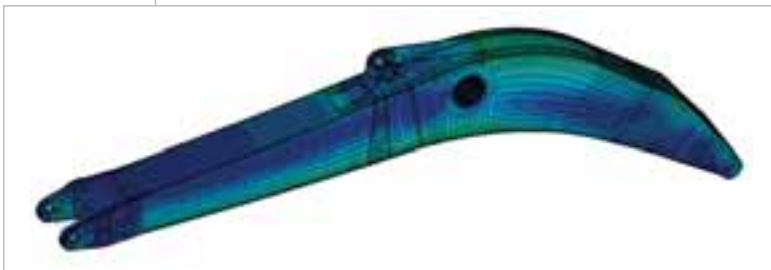
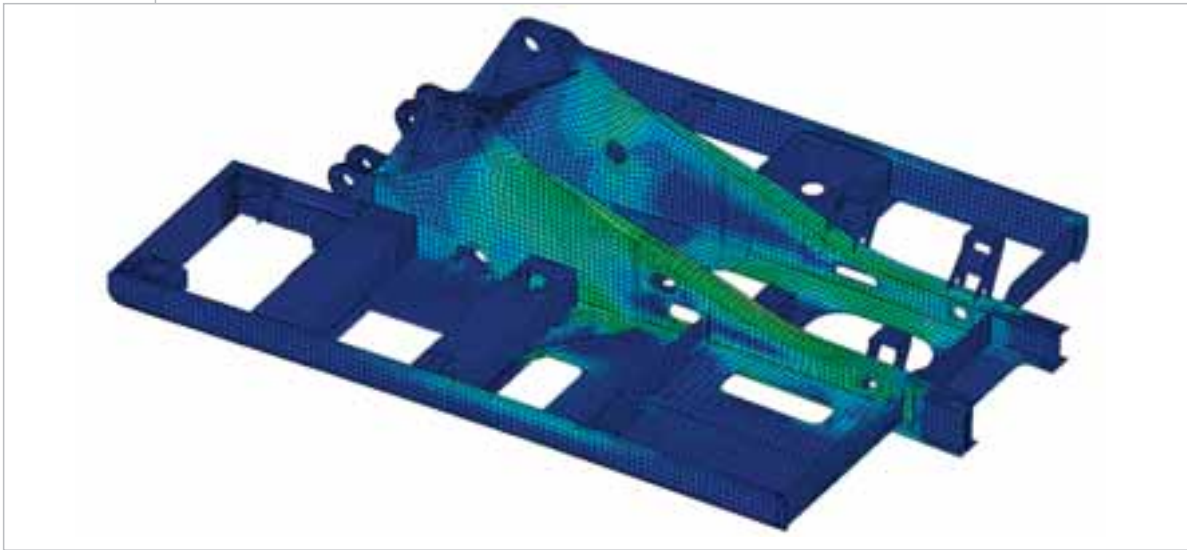

Booms and Arms have been redesigned using advanced CAD (Computer Aided Design) and FEM (Finite Elements Methodology) Systems to get higher strength **only** in those areas where stress is concentrated.

These sophisticated design methodologies are combined with the most advanced production technologies, providing high tensile steel plates that are cut, assembled and welded at the New Holland plant, which has held the prestigious "**Vision 2000**" **Quality Certification for many years.**

The same innovative guidelines, to achieve **Heavy Duty** maximum strength together with outstanding stress resistance, are applied in design and manufacture of the upper structure and the undercarriage.

T NEW BOOM & ARM

To further extend the Arm's durability, even in rocky applications, New Holland offers as standard Heavy Duty booms and arms and a robust Arm protection.



LIABILITY & DURABILITY CTION TECHNOLOGIES



T VARIABLE GAUGE UNDERCARRIAGE

The heavy duty “X” designed undercarriage assures perfect distribution of torsion stresses and provides superb strength, durability and reliability in all kind of application. Its length of 4400 mm, combined with a maximum extended gauge of 2890 mm, ensures machine stability and performance. The variable gauge allows for easy transport because the maximum width of machine can be reduced by 500 mm.

The practical and robust mechanical **variable gauge system** allows easy and quick gauge adjustments according to working or transportation requirements.

Four track guides mounted on each track, two in the centre and two in the front, are supplied as standard equipment.

They keep the chains on the rollers and provide protection while at the same time giving **extended durability, maximum efficiency and safety.**

T BEH VERSION

The E485B-BEH version (BEH stands for Bulk Excavator Heavy) features a shorter monoboom that has a length of 6.3 meters instead of 7.0 meters as on the LCH version. The BEH version is equipped with a short arm of 2,6 meters and a powered bucket linkage geometry. All these features provide customers with:

- an higher stability due to shorter boom and arm
- an higher breakout force, which averages + 3% with or without powerboost for both bucket and dipperstick;
- Possibility to use, in addition to the ones available for LCH version, a bigger 2.6 m³ bucket, with an advantage of +18% in volume of material moved in each cycle.

The undercarriage of both version LCH version (Long Carriage Heavy) and BEH is the same.

E485B - BEH is the ideal Heavy Duty machine capable to grant superior digging performances and higher productivity in the toughest applications for an increased return on your investment.

E485B OPERATOR



NEW ONE-HAND WINDSCREEN OPENING

One-touch lock release simplifies opening and closing the front window, while a new mechanism makes it lighter.



INSTRUMENT LAYOUT

In-cab switches and controls have been moved to the right-hand side in an easy to reach and more ergonomic position, thus improving operator comfort and convenience.



NEW A. E. P. MONITOR

The newly designed A.E.P. Monitor, features analogical gauges which provide one sight advice, regardless of the operating environment.

The digital Display Screen has been enlarged to further enhance visibility. Maintenance information is clearly displayed and the self-diagnostic function provides an early warning detection of malfunctions.

Details of any previous breakdown or malfunction are also stored.

R SAFETY AND COMFORT

NEW CAB INTERIOR

The interior of the cab has been completely redesigned to maximise operator comfort and to enable optimum operator performance. All switches and controls are now ergonomically positioned on the right side, easy to find and to reach. Enlarged side windows enhance the panoramic view. The radio and the new, more powerful and effective automatic air-conditioning system are standard equipment, creating an agreeable working atmosphere regardless of external weather conditions.

At the same time, new interior design and materials create an elegant feeling. Six silicon liquid filled viscous dampers minimise vibrations. The new, external safety structure of cab complies to ROPS and FOPS standards.



NEW COMFORTABLE SEAT

New comfortable contoured seat which can be adjusted in all directions, and back and forth, together with or independently of side consoles.

The armrests, integrated on side consoles, can be lifted/lowered into four different positions and inclined, enabling the operator to set the correct position for maximum convenience and comfort.



UNIQUE REAR CAMERA WITH “DEDICATED” IN CAB SCREEN

This is a very special option, enhancing active safety for both the operator and others on the job site. The **“dedicated screen”** is mounted inside the cab and **is unique to New Holland**. It allows the operator, whilst working, to simultaneously control both the job going on behind his machine and the machine's functional parameters, thanks to the **A.E.P.** display, which operates constantly. A really unique and outstanding feature in terms of **safety and comfort**.

E485B EASY MAIN

DESIGNED TO EFFECTIVELY CUT OPERATING COSTS

T CLEAN AND ACCESSIBLE LAYOUT

The new machine layout has been designed to make inspections, maintenance and servicing much easier and less time-consuming.

The engine oil filter, the fuel filter and the water separator are remote mounted and easy to reach from ground level. Both the fuel filter and the water separator, which removes contaminants and water, have an important function for engine performance and durability.

Cooling components (radiator, hydraulic oil cooler and intercooler) are now mounted in parallel, which means increased cooling efficiency for higher component reliability whilst being easier to check and clean.



The simplified layout of all vital components of the New Holland E485B under both the right and the left side panels makes maintenance much easier, less time consuming and less costly, and provides much better access for servicing. There is plenty of room in all compartments and most components are positioned in such a way to enable easy access from ground level. **An elegant and modern design added to state-of-the-art technology.**



AUTOMATIC CENTRALISED GREASING SYSTEM

An automatic centralised lubrication system is supplied as standard equipment.

It can be programmed in advance in terms of timing, frequency and quantity of grease released, thus supplying all wear points with the right quantity of grease at the right time.

A winning tool to **simultaneously reduce maintenance procedures and costs while improving machine reliability and durability as well as operator comfort.**

MENANCE & SERVICEABILITY

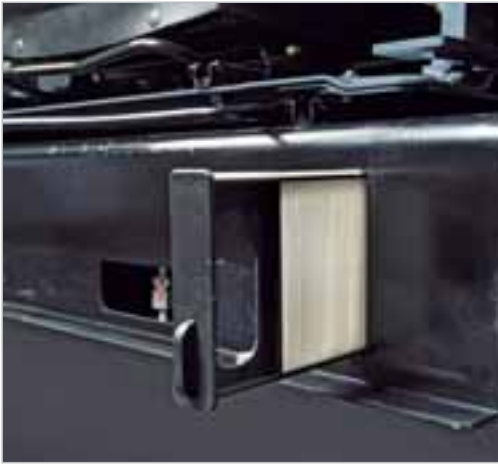

INSIDE CAB MAINTENANCE

■ Airconditioning filter, positioned under the seat, can be easily removed without tools and from ground level, for easy cleaning.



■ Detachable two-piece floormat with handles for easy removal. A floor drain is located under the mat to facilitate inside cab cleaning.



TOOL BOX

The tool box has been completely redesigned with a side-opening panel. It stores a new electric immersion type fuel pump, with automatic stop and alarm when the tank is full. The repositioning of the batteries (under the cooling components) and of the fuses (inside the cab) makes room in the compartment behind the cab for an additional wide and useful tool box.



FUSES

The fuses are inside the cab, protected from dust and water as well as being easy to reach and control.

E485B

SPECIFICATIONS



ENGINE TIER 3A

Net flywheel power (ECE R120)258 kW/346 hp
 Rated1850 rpm
 Make and modelHINO EB-P11C-UP
 Type...Diesel, Common Rail, direct injection, turbocharged, intercooler
 Total displacement10.5 l
 Number of cylinders6
 Bore x stroke120 x 145 mm
 Maximum torque at 1400 rpm.....1400 Nm

Remote engine oil filter for easy replacement.
Engine rpm electronic control with knob selector.
Automatic idling return selector with "Auto-Idling" controls in neutral
Start at -25° outside temperature as standard equipment
The engine complies with 97/68/EC Standard TIER 3A



ELECTRICAL SYSTEM

Operating voltage24 V
 Alternator60 A
 Starter motor6.0 kW
 Standard maintenance-free batteries2
 Capacity160 Ah



HYDRAULIC SYSTEM

Higher capacity pumps, to supply higher flow at lower rpm;
Redesigned Main Control Valve, with added 2nd dipper spool and new Fail Safe Functions;
Bigger radius piping with SAE flange ports;
H.A.O.A. (Hydrotronic Active Operation Aid) to get the best hydraulic output according to operator/ application demand;
E.S.S.C. (Engine Speed Sensing Control) device, for total installed hydraulic power exploitation;
D.O.C. (Dipper Optimised Control) thanks to the 2nd dedicated spool in the Control Valve and to the Conflux system;
C.P.B. (Continuous Power Boost) to allow the operator to use extra power when and how long it is needed;
A.E.P. (Advanced Electronic Processor) interacting with the operator for selecting and monitoring main working parameters, maintenance programmes, self diagnosis and operating data storage thanks to the new monitor with a larger digital display and analogical gauges;

Two working modes:

- **S** = for normal digging operation;
- **H** = when maximum power is required;

Two Attachments modes:

- **A** = for attachments which require double pump flow;
- **B** = for attachments, such as breaker, featuring one way flow only.

Standard double pump flow device and Diverter Valve automatically actuated while selecting A;

Super Fine hydraulic filter (8 micron) to grant perfect oil filtration, contributing to increase oil change interval

Main pumps:

two variable delivery pumps with electronic delivery adjustment

With controls on neutral, the pumps automatically move to displacement position "0".

Maximum delivery.....2 x 370 l/min

Piloting circuit gear type pump

Maximum delivery30 l/min

Maximum operating pressure:

Equipment.....31.4 MPa
 Power Boost34.3 MPa
 Travel.....34.3 MPa
 Swing.....25.0 MPa
 Hydraulic cylindersdouble effect
 - Lift (2) - Bore x Stroke.....170 x 1590 mm
 - Penetration (1) - Bore x Stroke.....190 x 1970 mm
 - Bucket (1) - Bore x Stroke170 x 1300 mm



TRANSMISSION

Typetwo-speed hydrostatic
 Motorsaxial piston double displacement type, collapsible into track carriage
 Brakesoil bath disc type, automatically applied and hydraulically released
 Final drivesoil bath, planetary reduction
 Maximum slope.....70% (35°) continuous
 Travel speeds:
 slow.....0 to 3.5 km/h
 high.....0 to 5.6 km/h
 Drawbar pull.....430 kN

"Automatic DownShift" device: with selector on "fast" in case of need for more traction force adjusts travel motors to maximum displacement.



SWING

Swing motorstwo axial piston type
 Swing brake.....oil bath disc type, automatically applied and hydraulically released
 Final driveoil bath, 2-stage planetary reduction
 Slew ringgrease bath type
 Swing speed8.0 rpm



CAB AND CONTROLS

Transparent opening roof.

Standard automatic conditioning

Controlspiloted

Two cross travel levers control all equipment movements and superstructure swing.

Two pedals with hand levers control all track movements, counter-rotation included.

A safety lever neutralises the piloting circuit completely.



UNDERCARRIAGE

Typevariable gauge
 X-design undercarriage
 Sealed bushing reinforced track HD chain
 Chain link pitch229 mm

E485B-LCH-E485B-BEH

Track rollers (each side)	9
Carrier rollers (each side)	3
Length of track on ground (mm)	4400
Minimum gauge (mm)	2390
Maximum gauge (mm)	2890
Shoes available (mm)	600-700 800-900



CAPACITIES

	litres
Lube oil50
Coolant41
Fuel633
Hydraulic System555

E485B-LCH

DIMENSIONS (mm) - OPERATING WEIGHT

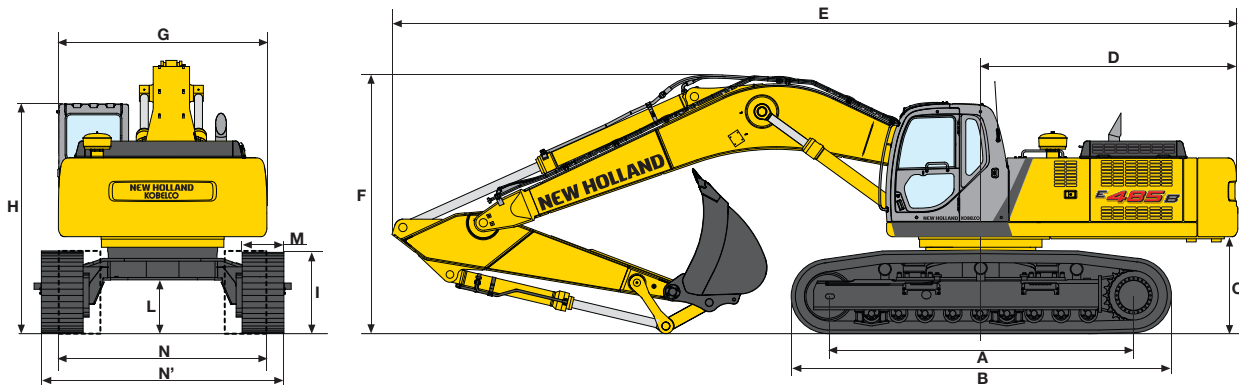

VERSION	A	B	C	D	E	F	G	H	I	L
					(1) 12100	(1) 3500				
E485B-LCH	4400	5460	1460	3700	(2) 12080	(2) 3520	3000	3510	1220	740
					(3) 12070	(3) 3500				

Dipperstick: (1) 2900 mm - (2) 3450 - (3) 4040 mm

	E485B-LCH				
M - Shoe width	mm	600	700	800	900
N - Minimum width	mm	2990	3090	3190	3290
N' - Maximum width	mm	3490	3590	3690	3790
Operating weight	kg	48600	49150	49700	50250
Specific ground pressure	bar	0.90	0.78	0.70	0.62

DIGGING PERFORMANCE

ONE - PIECE BOOM = 7000 mm

DIPPERSTICK		2900	3450	4040
A	mm	11540	12060	12560
A'	mm	11280	11810	12320
B	mm	7140	7690	8280
B'	mm	6974	7540	8150
C	mm	10730	10990	11050
D	mm	7400	7650	7740
E	mm	5240	5170	5190

BREAKOUT FORCE:				
BUCKET	daN	24800	24800	24800
DIPPERSTICK	daN	22640	19985	17945

WITH POWER BOOST ON				
BUCKET	daN	27000	27000	27000
DIPPERSTICK	daN	24780	21820	19580

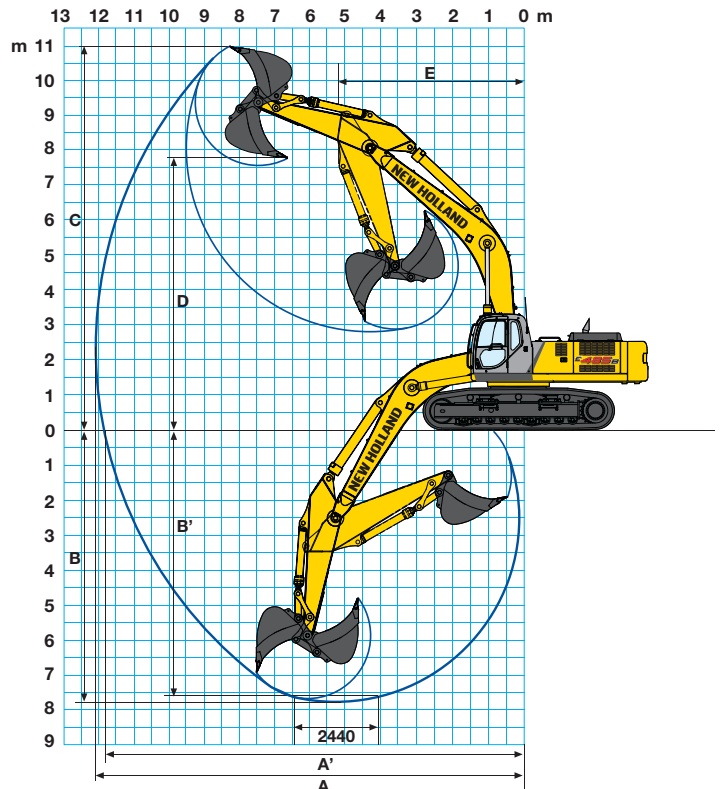

E485B-BEH

DIMENSIONS (mm) - OPERATING WEIGHT

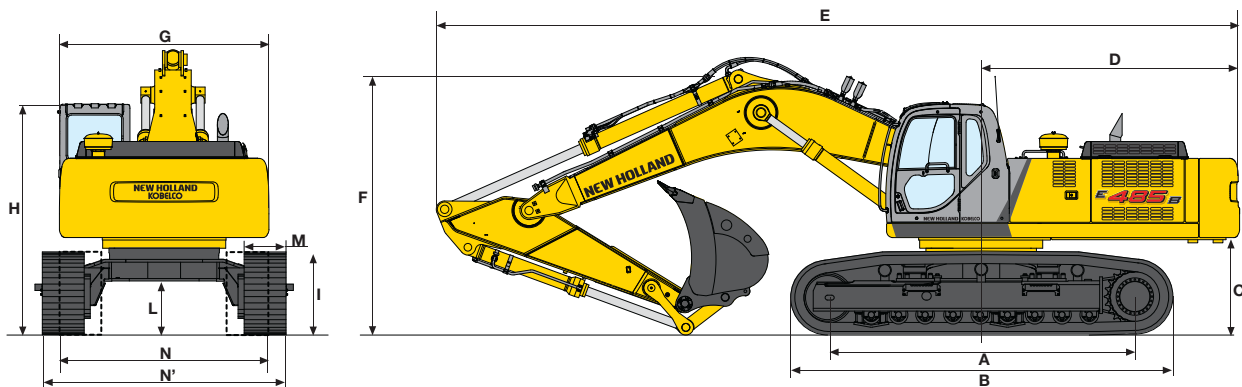

Version	A	B	C	D	E	F	G	H	I	L
E485B-BEH	4400	5460	1460	3700	11500	3830	3000	3510	1220	740

		E485B - BEH			
M - Shoe width	mm	600	700	800	900
N - Minimum width	mm	2990	3090	3190	3290
N' - Maximum width	mm	3490	3590	3690	3790
Operating weight	kg	47950	48500	49050	49600
Specific ground pressure	bar	0.89	0.77	0.68	0.61

DIGGING PERFORMANCE

BEH - ONE-PIECE BOOM = 6300 mm

DIPPERSTICK		2600
A	mm	10610
A'	mm	10350
B	mm	6260
B'	mm	6085
C	mm	10150
D	mm	6940
E	mm	4720

BREAKOUT FORCE:		
BUCKET	daN	25390
DIPPERSTICK	daN	23250

WITH POWER BOOST ON		
BUCKET	daN	27740
DIPPERSTICK	daN	25390

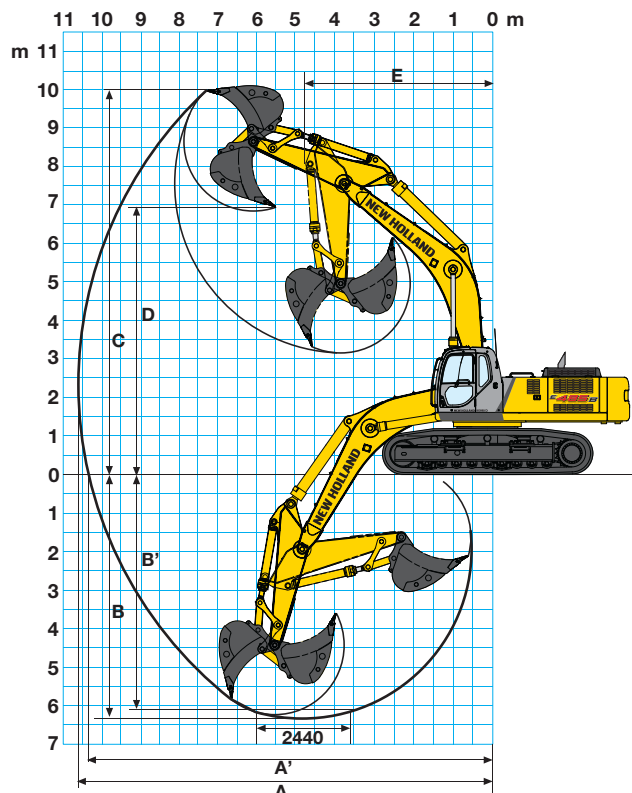

E485B

LIFTING CAPACITY

VALUES ARE EXPRESSED IN TONNES

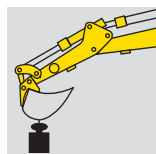

RADIUS OF LOAD

3.0 m		4.5 m		6.0 m		7.5 m		9.0 m		AT MAX. REACH		REACH m
FRONT	SIDE	FRONT	SIDE	FRONT	SIDE	FRONT	SIDE	FRONT	SIDE	FRONT	SIDE	

E485BLCH DIPPERSTICK 2900 mm

HEIGHT													
+7.5 m													
+6.0 m							8.9 *	8.9 *	8.4 *	7.9	8.4 *	7.4	9.3
+4.5 m			16.3 *	16.3 *	12.0 *	12.0 *	10.0 *	10.0 *	8.4 *	7.7	8.5 *	6.7	9.8
+3.0 m			20.4 *	20.4 *	14.1 *	14.0	11.1 *	10.0	9.4 *	7.5	8.8 *	6.3	10.0
+1.5 m			14.8 *	14.8 *	15.7 *	13.3	12.1 *	9.6	10.0 *	7.3	9.1 *	6.2	9.9
0 m			18.7 *	18.7 *	16.5 *	13.0	12.7 *	9.3	10.4 *	7.1	9.5 *	6.4	9.7
-1.5 m	14.3	14.3 *	22.3 *	20.2	16.5 *	12.9	12.8 *	9.2	10.2 *	7.1	10.0 *	6.9	9.1
-3.0 m	23.1 *	23.1 *	20.7 *	20.5	15.7 *	13.0	12.1 *	9.3			10.5 *	8.0	8.3
-4.5 m	23.5 *	23.5 *	17.7 *	17.7 *	13.5 *	13.3					10.8 *	10.5	7.1
-6.0 m													

E485BLCH DIPPERSTICK 3450 mm

HEIGHT													
+7.5 m									7.5 *	7.5 *	6.8 *	6.8 *	9.2
+6.0 m							8.2 *	8.2 *	7.7 *	7.7 *	6.8 *	6.7	9.9
+4.5 m					11.0 *	11.0 *	9.3 *	9.3 *	8.3 *	7.8	6.9 *	6.1	10.3
+3.0 m			18.8 *	18.8 *	13.2 *	13.2 *	10.5 *	10.0	8.9 *	7.5	7.3	5.7	10.5
+1.5 m			18.2 *	18.2 *	15.0 *	13.4	11.6 *	9.6	9.6 *	7.2	8.0 *	5.6	10.5
0 m	7.0 *	7.0 *	19.1 *	19.1 *	16.1 *	12.9	12.4 *	9.3	10.1 *	7.0	8.8 *	5.8	10.2
-1.5 m	13.0 *	13.0 *	22.6 *	20.0	16.4 *	12.7	12.7 *	9.1	10.2 *	6.9	9.2 *	6.2	9.7
-3.0 m	19.9 *	19.9 *	21.4 *	20.2	15.9 *	12.7	12.3 *	9.1			9.6 *	7.1	9.0
-4.5 m	26.3 *	26.3 *	19.0 *	19.0 *	14.3 *	13.0	10.8 *	9.3			10.1 *	8.8	7.8
-6.0 m			14.5 *	14.5 *	10.5 *	10.5 *					10.1 *	10.1 *	6.1

E485BLCH DIPPERSTICK 4040 mm

HEIGHT													
+7.5 m									6.6 *	6.6 *	5.4 *	5.4 *	9.8
+6.0 m									7.0 *	7.0 *	5.4 *	5.4 *	10.4
+4.5 m							8.5 *	8.5 *	7.6 *	7.6 *	5.6 *	5.5	10.8
+3.0 m			17.0 *	17.0 *	12.2 *	12.2 *	9.8 *	9.8 *	8.4 *	7.5	5.9 *	5.2	11.0
+1.5 m			20.5	20.5 *	14.2 *	13.5	11.0 *	9.6	9.1 *	7.2	6.5 *	5.1	11.0
0 m	8.1 *	8.1 *	20.6 *	20.2	15.6 *	12.9	12.0 *	9.2	9.7 *	7.0	7.3	5.2	10.7
-1.5 m	12.5 *	12.5 *	22.7 *	19.9	16.2 *	12.6	12.5 *	9.0	10.0 *	6.8	8.5 *	5.6	10.3
-3.0 m	17.9 *	17.9 *	22.0 *	19.9	16.1 *	12.6	12.4 *	9.0	9.8 *	6.8	9.0 *	6.2	9.6
-4.5 m	25.0 *	25.0 *	20.1 *	20.1 *	15.0 *	12.7	11.5 *	9.1			9.5 *	7.6	8.5
-6.0 m	23.0 *	23.0 *	16.5 *	16.5 *	12.3 *	12.3 *					9.9 *	9.9 *	7.0

E485BBEH DIPPERSTICK 2600 mm

HEIGHT													
+7.5 m											10.0 *	10.0 *	7.5
+6.0 m							10.1 *	10.1 *			10.0 *	9.2	8.3
+4.5 m			16.6 *	16.6 *	12.8 *	12.8 *	10.9 *	10.7			10.1 *	8.2	8.8
+3.0 m			20.8 *	20.8 *	14.8 *	14.6	12.0 *	10.3	10.4 *	7.7	10.4 *	7.7	9.0
+1.5 m			23.3 *	21.5	16.4 *	13.9	12.9 *	10.0			10.8 *	7.6	9.0
0 m			23.8 *	21.1	17.2 *	13.6	13.3 *	9.8			11.2 *	7.9	8.7
-1.5 m	20.2 *	20.2 *	22.9 *	21.1	17.0 *	13.5	13.1 *	9.7			11.7 *	8.7	8.1
-3.0 m	28.0 *	28.0 *	20.5 *	20.5 *	15.4 *	13.6					12.1 *	10.6	7.2
-4.5 m			15.8 *	15.8 *							12.0 *	12.0 *	5.7

As per ISO 10567 with excavator equipped with bucket. The indicated load is no more than 87% of hydraulic system lift capacity or 75% of static tipping load. Values marked with an asterisk are limited by the hydraulic system.



STANDARD EQUIPMENT

- Automatic fuel electrical pump
- Auto-Idling device
- Automatic air conditioner
- Batteries maintenance free
- Centralised automatic lubrication
- Continuous Power Boost device
- Cushioning on hydraulic cylinders
- Dipperstick protection
- Double pump flow
- Engine rpm electronic control
- Foot pedal or lever travel control
- Front seal hydraulic piping and connections
- Grease bath swing ring
- H.A.O.A. (Hydrotronic Active Operation Aid)
- HD chains
- Horn
- Hydraulically suspended cab with transparent opening roof
- Main control valve with two dipper spools and antidrift valves
- Mechanical or pneumatic seat
- Multi-function monitor
- One piece boom or BEH
- Pressure drain switch
- Radio set
- Rear mirror
- Swing and travel motors with automatic disc type brakes
- TIER 3A emissioned diesel engine
- Tool kit
- Two travel speed with Automatic Down Shift device
- Two working lights on boom and one on upperstructure
- Two-speed intermittent operation windshield wiper

OPTIONS

- Antitheft device
- Biological hydraulic oil
- Cab additional lights and rain protection
- Cab FOPS
- Cab front guard
- Customer colour
- Hammer and crusher circuit
- HD Dipperstick:
 - 2600 mm (BEH version)
 - 2900 mm
 - 3450 mm
 - 4040 mm
- Hydraulic quick coupler provision
- Lower frame cover
- Multipurpose rock and heavy duty buckets with bucket/boom adjustment device
- Object handling kit
- Rear view camera with dedicated display (replacing rear mirror)
- Rotating bucket circuit
- Shoes:
 - LCH/BEH: 600 - 700 - 800 - 900 mm

Note: standard and optional equipment may vary by country. Consult your NEW HOLLAND dealer for specific details.

ONE PIECE BOOM

BUCKETS			E485B LCH			E485B BEH
Width (mm)	Capacity (m ³) (ISO 7451)	Weight (Kg)	Dipper mm			Dipper mm
			2900	3450	4040	2600
1320	1.6	1231				
1420	1.8	1328				
1550	2.0	1409				
1670	2.2	1468				
1740	2.6	1850	-	-	-	

 General digging work (specific weight of material < 1.8 t/m³)

NEW HOLLAND. THE POWER OF A GLOBAL BRAND

New Holland is a global brand with a key position in the Construction Equipment business. It supplies a complete range of 13 product lines and 80 basic models split into Compact line and Heavy line. It operates in all the main markets, such as Europe, North and Latin America, Africa, Asia and Middle East with the same technology and under the same logo and brand.

It manufactures durable, safe and productive machines aimed at supporting customers in developing their own business.

Dealers are company partners. They play an important role support the brand in their territories through

intense professional relationship with Customers.

New Holland is reinforced by its global alliance

with Kobelco: world leader in hydraulic excavator technology.



AT YOUR OWN DEALERSHIP

The information contained in this brochure is intended to be a general nature only. The NEW HOLLAND KOBELCO CONSTRUCTION MACHINERY S.p.A. company may at any time and from time to time, for technical or other necessary reasons, modify any of the details or specifications of the product described in this brochure. Illustrations do not necessarily show products in standard conditions. The dimensions, weights and capacities shown herein, as well as any conversion data used, are approximate only and are subject to variations within normal manufacturing techniques.

Published by NEW HOLLAND KOBELCO CONSTRUCTION MACHINERY S.p.A.
Printed in Italy - MediaCross Firenze - Cod. 31 459GB - Printed 02/11

Printed on recycled paper
CoC-FSC 000010 CQ Mixed sources



ELEMENTAL
CHLORINE
FREE
GUARANTEED



BUILT AROUND YOU

www.newholland.com